

QUICK GUIDE

AP 650I/750I



Online Support: www.fujixerox.com.my/support

Website : <http://www.fujixerox.com.my>

INTRODUCTION

The main objective of compiling this Quick Guide is to serve as an easy reference to customers. We understand customers are tight up with daily schedules and can only learn up limited machine feature in the training sessions. Thus, we hope this Quick Guide will provide you with all the essential feature should you encounter any operation problems with the machine.

Kindly contact the following number :

For General Service & Supplies
Toll Free : 1-300-88-1163

Or

To contact us kindly email to us at:

mysallcto@mys.fujixerox.com

TABLE OF CONTENTS

Section A: Copy Features

1. 2-Sided Copy
2. IC Copy – 2 Methods
3. Reduce / Enlarge
4. Finishing
5. Edge Erase
6. Margin Shift
7. Book Copying
8. Multi-Up
9. Booklet Creation
10. Repeat Image + Original Size

Section B : Scan to FTP / SMB Feature

Section C : Scan to Mailbox Feature

Section D : Printing Features

Section E : Maintenance

1. Checking Billing Meter
2. Checking Consumables Status
3. Replacing Toner Cartridge
4. Replacing Waste Toner Container
5. Clearing Paper Jams

Online Service & Support Request
Online Support Assistant

Section A: COPY

2-Sided Copying

Steps: 1. Load document on feeder

2. Goto [Scan Options Tab]

3. Select required options:

1→ 1 Sided

Makes a copy of a 1 sided document on one side of the paper.

1→ 2 Sided

Makes a copy of a 1 sided document on both sides of the paper.

2→ 2 Sided

Makes a copy of a 2 sided document on both sides of the paper.

2→ 1 Sided

Makes a copy of a 2 sided document on one side of the paper.

4. Press Start

IC Copy – 2 methods

I.) Copy IC both sides on the same page

1. Goto [Basic Copying Tab] – Select A4 Paper (Portrait) – Press Save
2. Goto [Image Quality Tab] – Select Original Type: Text/Photograph – Press Save
3. Put IC onto platen glass (Top Left corner) and press Start
4. Take the printed copy and load it to Tray 5 (Bypass)
(Note: Do not change paper order)
5. Open the Cover and Flip IC to the opposite point of A4, press Start

II.) Copy IC both sides front and back page

1. Goto [Basic Copying Tab] – Select A4 Paper (Portrait) – Press Save
2. Goto [Image Quality Tab] – Select Original Type: Text/Photograph – Press Save
3. Goto [Scan Options Tab] – Select 2 Sided – Change to 1 → 2 – Press Save
4. Load the first side of your IC onto platen glass (Top Left corner) and press Start
5. Open the Cover and Flip IC to the opposite point of A4, press Start

Reduce/ Enlarge

(Allows to select/specify the reduction/enlargement ratio within range of 25 - 400%)

- Steps:
1. Load document on feeder
 2. Goto [Basic Copying Tab]
 3. Select Reduce / Enlarge
 4. Select copy ratio
 5. Select Save
 6. Press Start

“ 100%

Copies are made at the same size as the original document.

“ Auto%

The copy ratio is automatically set based upon the document and paper sizes, and the document is copied to fit in the selected paper.

“ Presets % (7 Types)

Select from among 7 preset ratios.

“ Variable %

You can enter any ratio for copying. Set the ratio within the range from 25 to 400% in 1% increments.

Finishing

(Allows to sort copy outputs collated or uncollated)

- Steps:
1. Load document on feeder
 2. Goto [Output Format Tab]
 3. Select Finishing
 4. Select required options
 5. Select Save
 6. Press Start

“ Auto

Copies are output collated

“ Collated / Stapling / Punching

The machine can output sheets sorted into sets that are arranged in page order.

“ Uncollated

The machine can output the specified number of copies and sort sheets by page

Edge Erase

(To erase shadows/unwanted marks e.g. hole punch from edges or centre of page)

- Steps:
1. Load document on feeder
 2. Goto [Scan Options Tab]
 3. Select Edge Erase
 4. Change the default from Normal to Edge Erase
 5. Use the arrow up or down button to set the amount of area to be erased
 6. Select Save
 7. Press Start

Image Shift

(Allows to change the position of the image on an output page)

- Steps:
1. Load document on feeder
 2. Goto [Scan Options Tab]
 3. Select Image Shift/Variable Shift
 4. Select any items for image shift options
- Auto Center; Corner Shift or Variable Shift
 5. Select Save twice
 6. Press Save

Book Copying

(To copy bound documents using document glass into 2 separate pages)

- Steps:
1. Open and place book at top left on the platen glass
 2. Goto [Scan Option Tab]
 3. Select Book Copying
 4. Select required option
 - Left Page then Right OR Right Page then Left
 5. Select Save
 6. Press Start

Multi-up

(To copy 2, 4 or 8 documents onto 1 sheet of paper. Document Centre will automatically reduce/enlarge the images)

- Steps:
1. Load document on feeder
 2. Goto [Output Format Tab]
 3. Select Multiple-Up
 4. Select 2up, 4up or 8up
 5. Select required Image Order
 6. Select Save
 7. Press Start

Booklet Creation

(To print the images side by side on both sides of each pages in the correct order to make a booklet. Fold the copies in half and staple in the middle to create a finished booklet)

- Steps:
1. Load document on feeder
 2. Goto [Output Format Tab]
 3. Select Booklet Creation
 4. Select Left Bind/ Top Bind or Right Bind
 5. Select Save
 6. Goto [Basic Copying Tab]
 7. Select paper tray that contains of Landscape paper
 9. Press Start

Repeat Image + Original Size

(Print original image repeatedly on one sheet of paper)

- Steps:
1. Load document on platen glass
 2. Goto [Output Format Tab]
 3. Select Repeat Image
 4. Select Auto Repeat
 5. Select Save
 6. Goto [Scan Options Tab]
 7. Select Originals Size
 8. Set document size using left-right for value "X" and top-bottom for value "Y"
 9. Select Save
 10. Press Start

Section B: SCAN TO PC (FTP/SMB)

Scan to PC (FTP/SMB) – From Address Book

- Steps:
1. Press All Services button
 2. Select Scan to FTP/SMB
 3. Select Address Book
 4. Select Recipient Name
 5. Select Save
 6. Under [Basic Scanning Tab], select File Format
 7. Goto [Output Format Tab]
 8. Select File Name (example: PDF)
 9. Key in File Name
 10. Select Save
 11. Press Start

Section C: SCAN TO MAILBOX

Scan to Mailbox

(This feature scan and save document(s) on the machine mailbox an import/retrieve scanned documents using specific program.)

- Steps:
1. Press All Services button
 2. Select Scan to Mailbox
 3. Select your own Mailbox Number
 4. Goto [Scan Options Tab] to change optional settings:
 - Select 2 sided originals (Head to Head)
 - Select Scan Size
 - Select Reduce/Enlarge
 5. Goto [Output Format Tab]
 6. Select Document Name
 7. Key in Document Name
 8. Select Save
 9. Press Start

Retrieving / Importing Scanned Documents

- Steps:
1. Go to START > PROGRAMS > FUJI XEROX > UTILITY > MAILBOX VIEWER2
 2. Identify the scanner (by printer name) and press Select Scanner button
 3. Enter your Mailbox Number into the text box (e.g. 1)
 4. Enter your 4-digit password (if any)
 5. Click on Open Mailbox button
 6. Click 'Import' to import the scanned file
 7. Select Close button once completed file transfer
 8. By default the Scanned documents are stored in *My Documents folder, Fuji Xerox, Network Scan*

Section D: PRINTING

Printing Job Types

Main Features

1. Normal Print
To print documents from your PC as a normal print job
2. Secure Print
Allows you to set user ID and password for the document on your PC. When send for printing, it temporary stores the documents on the machine and only prints out when you select your user ID and password on the physical machine
3. Sample Print
Before printing multiple sets of a document, you may print one sample set for trial before proceeding the next sets
4. Save to Mailbox
Allows you to store your documents in your own mailbox before printing out
5. Delay Print
 - Allows you to print your documents at a specific time

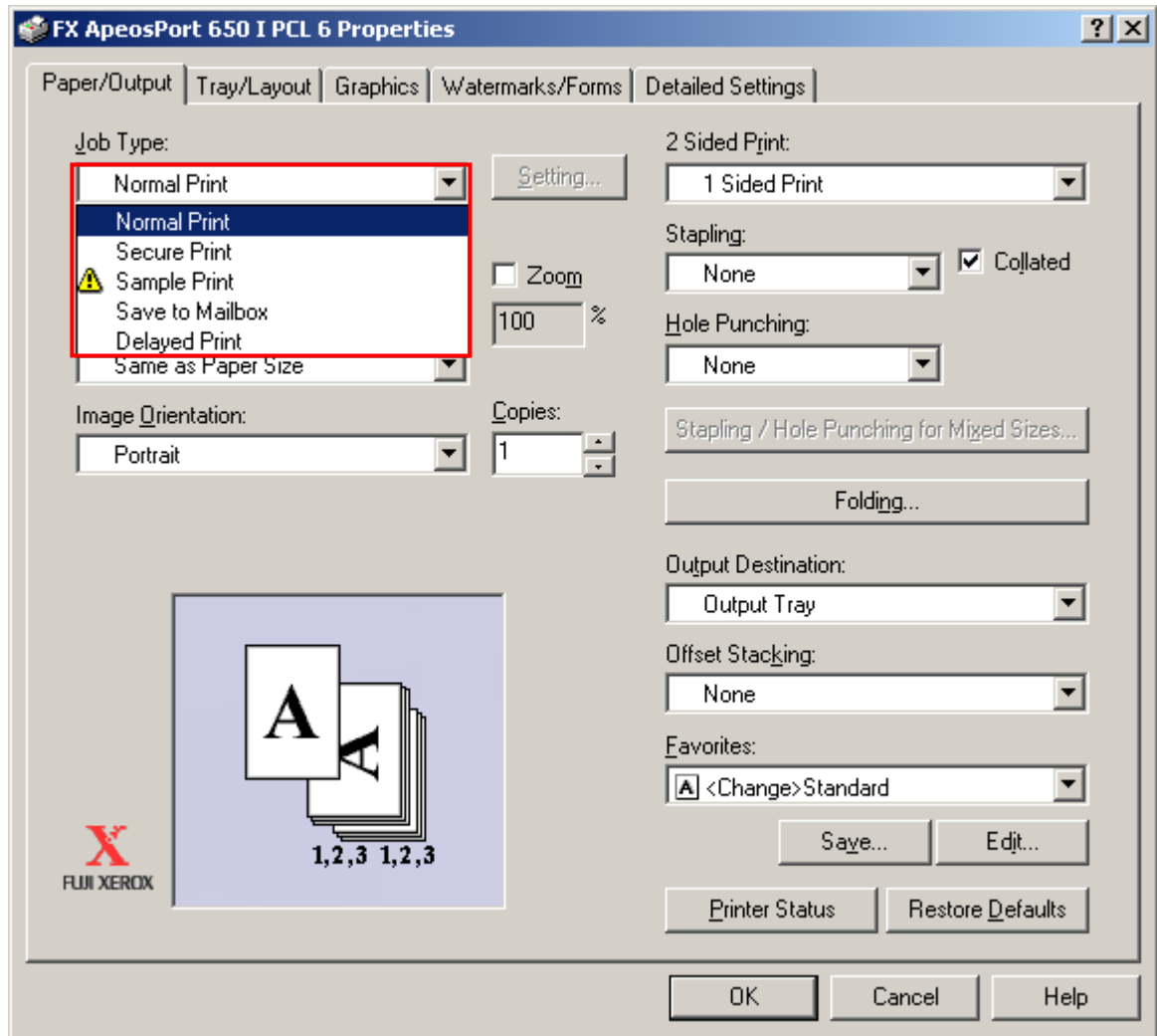

Normal Print

- Steps :
1. Go to File, Select Print
 2. Select Printing Preferences
 3. Under Job Type, Select Normal Print
 4. Select OK

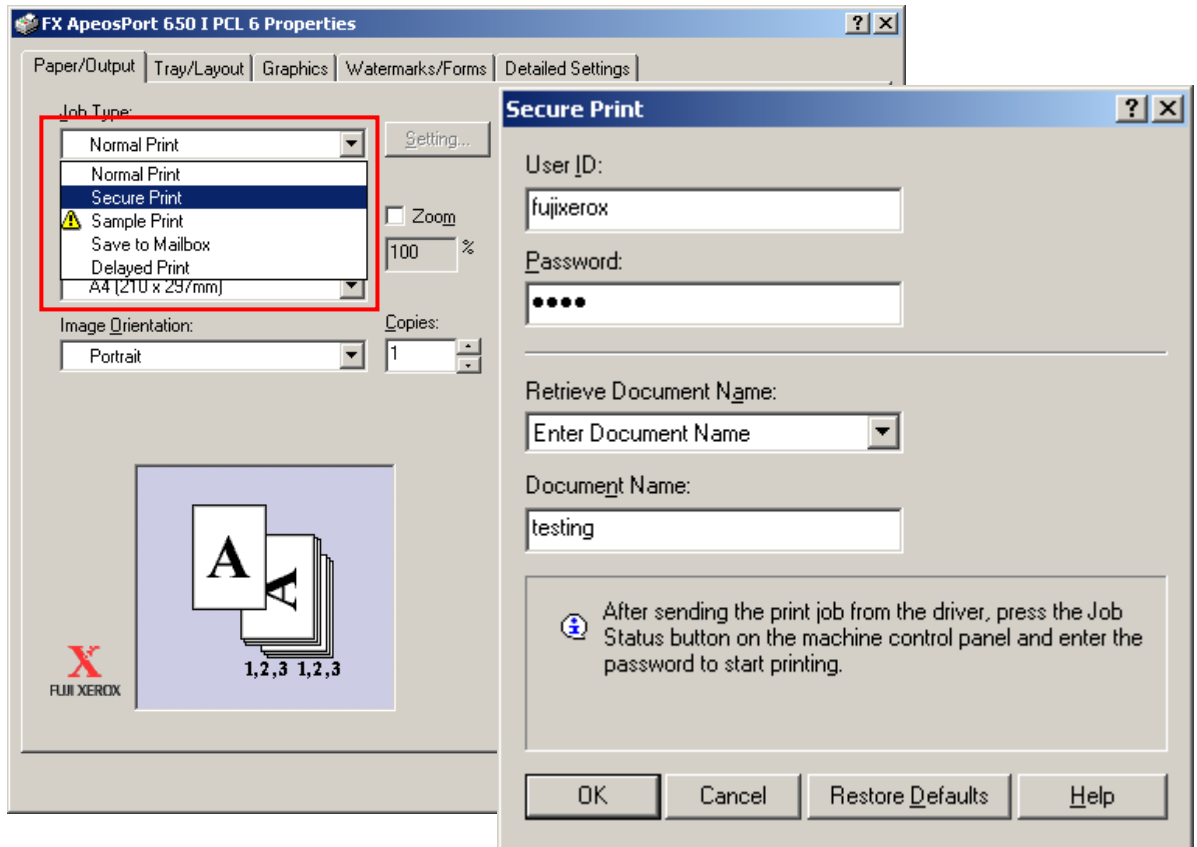

Secure Print

- Steps :
1. Go to File, Select Print
 2. Select Printing Preferences
 3. Under Job Type, Select Secure Print
 4. Under Secure Print Message Box, key in:-
 - User ID
 - Password
 - Document Name

Secure Print (Document Retrieval)

- Steps:
1. Select Job Status Button (at the machine)
 2. Click Stored Documents
 3. Select User ID
 4. Select Document List
 5. Key-in Password and Confirm
 6. Select Job and Print

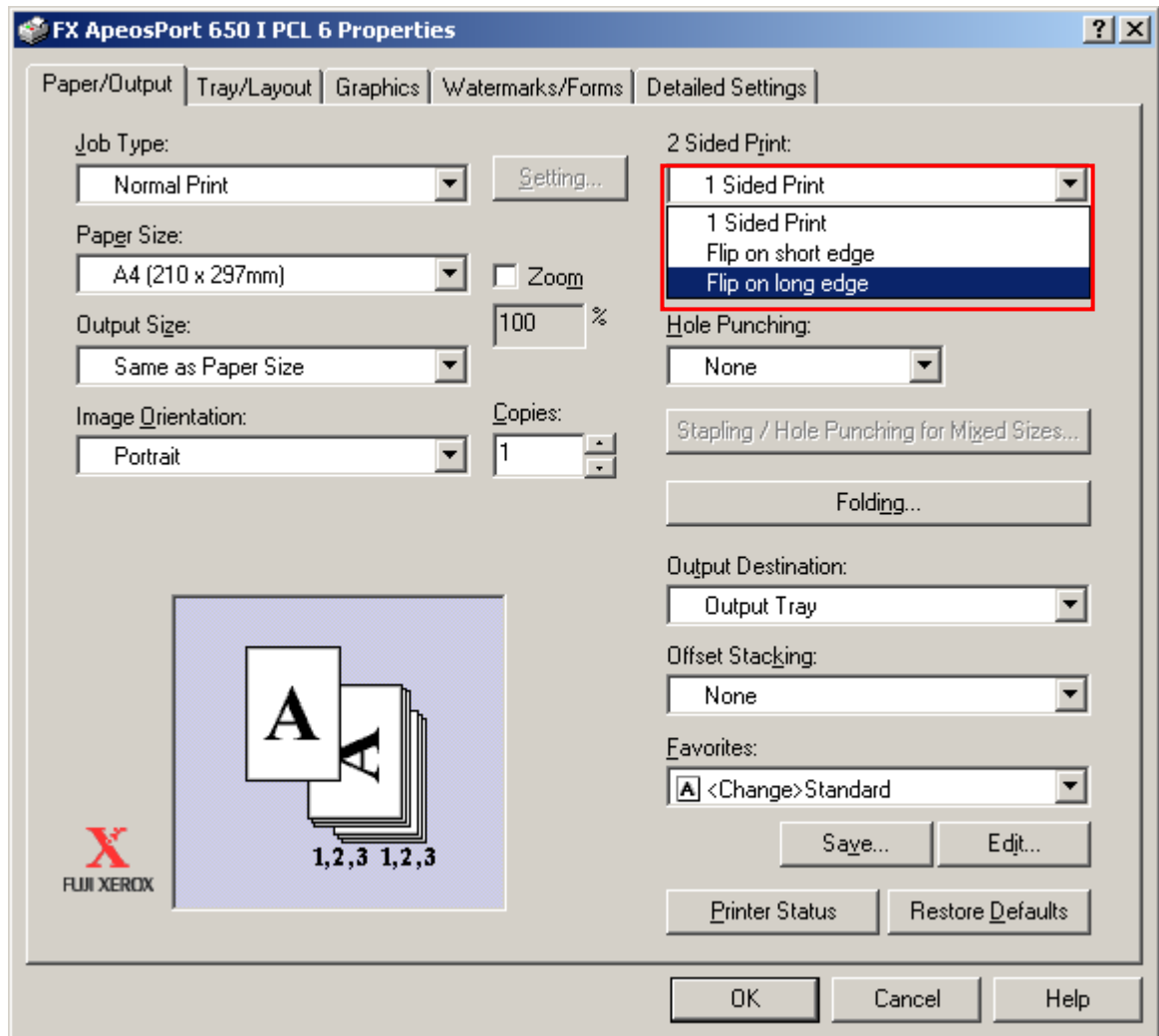

2-sided Print

- Steps :
1. Go to File, Select Print
 2. Select Printing Preferences
 3. Under 2 Sided Print, Select Flip on Long Edge or Short Edge
 4. Select OK

Note: Flip on Long Edge is known as Head to Head
 Flip on Short Edge is known as Head to Toe

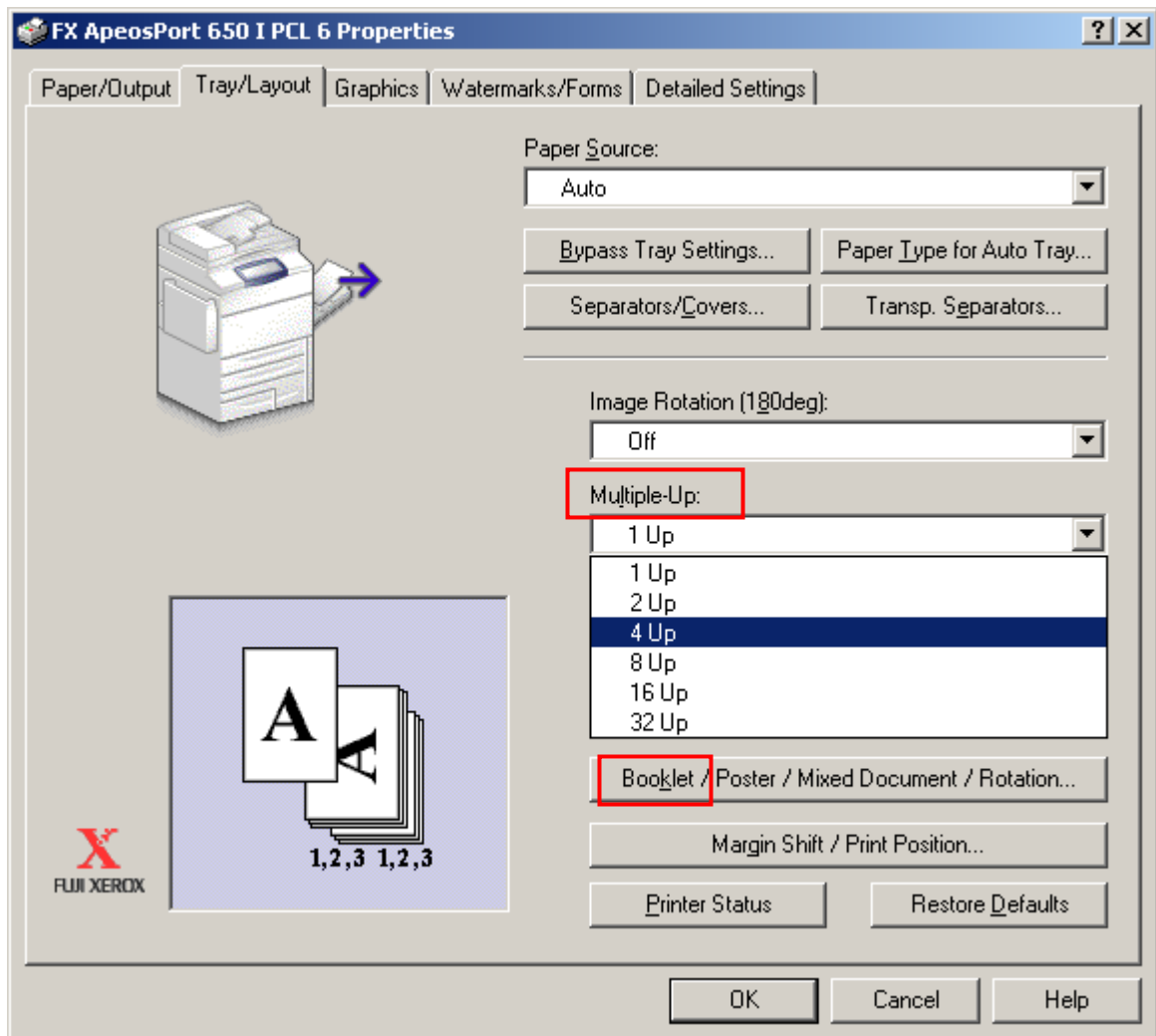

Multi-Up

- Steps :
1. Go to File, Select Print
 2. Select Printing Preferences
 3. Goto [Tray/Layout Tab]
 4. Select Multiple-Up (1Up to 32 Up)
 5. Select OK

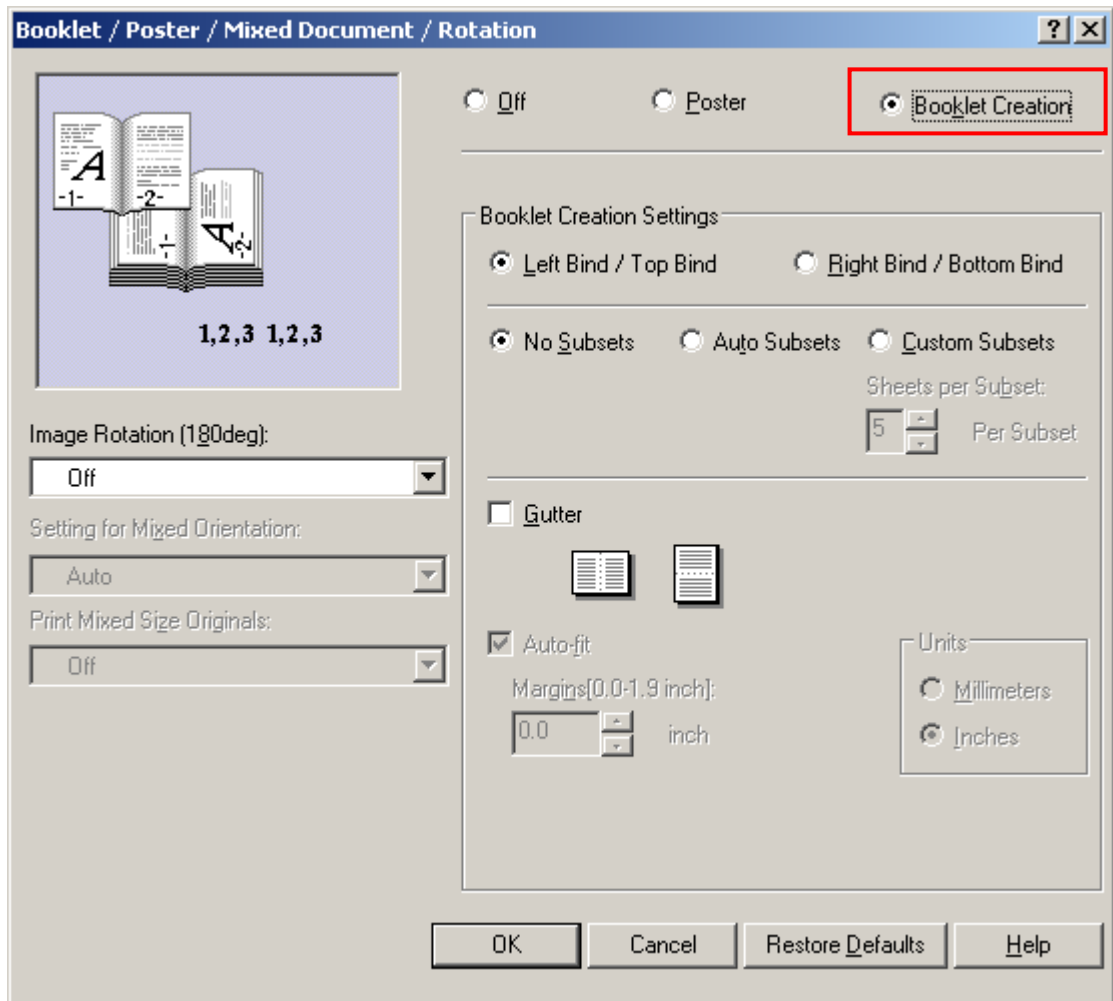

Booklet Printing

- Steps :
1. Go to File, Select Print
 2. Select Printing Preferences
 3. Goto [Tray/Layout Tab]
 4. Select Booklet/ Poster/ Mix Document/ Rotation
 5. Select Booklet Creation Option Button
 6. Select OK to the pop-up message box
 7. Select OK

Section E: Maintenance

Checking Billing Meter

1. Press <Machine Status> button on the control panel.
2. Select Billing Meter/Print Report Tab
3. Select Billing Meter
4. Press Close button once done

Notes:

Serial Number – Displays the serial number of the machine

Meter 1 – Meter 2 + Meter 3

Meter 2 – Number of B/W copies + Number of B/W prints

Meter 3 – Number of B/W prints

Checking Consumables

You can check the status of consumables in the [Consumables] screen. The status of consumables is shown as "Ready", "Replace Soon", or "Replace Now". For toner, the amount is shown in percentage (0 to 100%).

- Steps:
1. Press <Machine Status> button on the control panel
 2. Select Consumables Tab
 3. Press Close button once done

*Consumables Status Reminder:

REPLACE SOON: To Order New Cartridges

REPLACE NOW: To Replace Immediately and Place New Order for Standby

How to Replace Toner Cartridge

1. Open the toner cover.

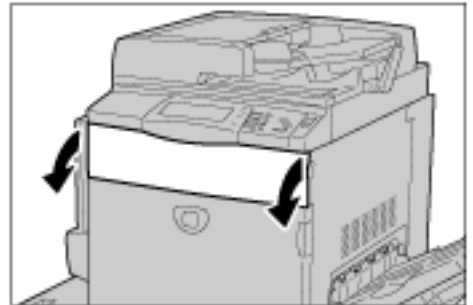

2. Hold the lower part of the toner cartridge of the color indicated in the message and gently pull it out

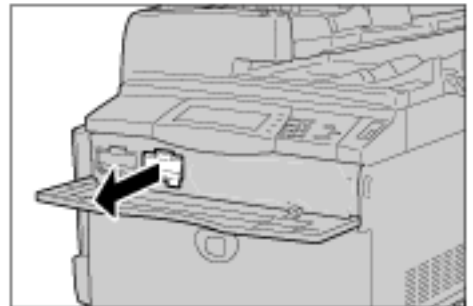

3. Remove the toner cartridge by holding the handle on the top of the cartridge while gently pulling it out.

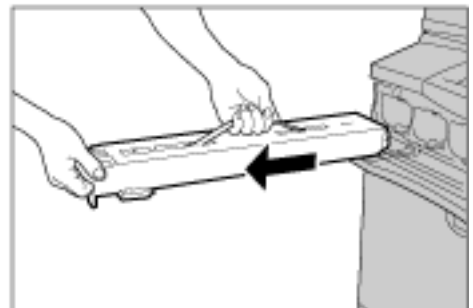

4. Take out the new toner cartridge of the same color as the old one from its box, and gently tilt the cartridge up and down, and then left and right several times.

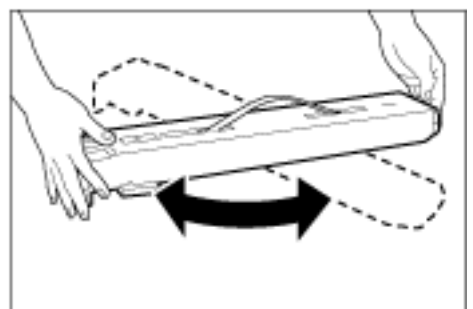

5. Insert the toner cartridge in gently until it comes to a stop.

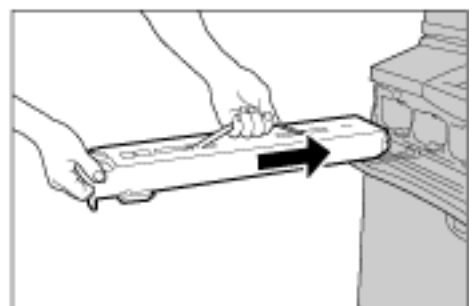

6. Close the toner cover.

How to Replace Waste Toner Container

1. Make sure that the machine has stopped before opening the front cover.



2. Open the waste toner container cover.

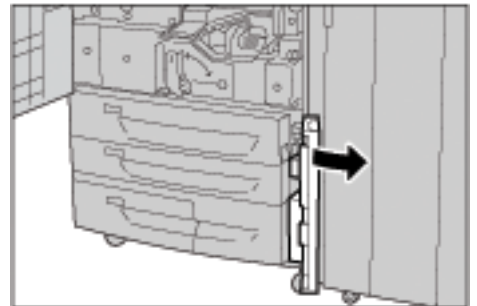

3. Grip the handle of the waste toner container and pull out about half of it.

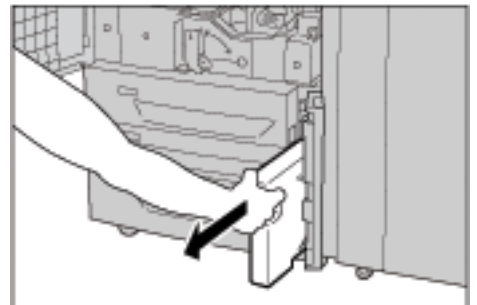

4. Hold the center part on the top of the container, and then remove it.

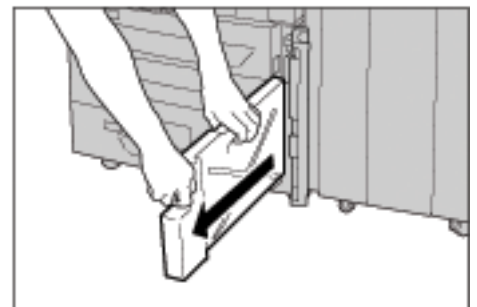

5. Hold the used waste toner container firmly with both hands and put it into the provided plastic bag.

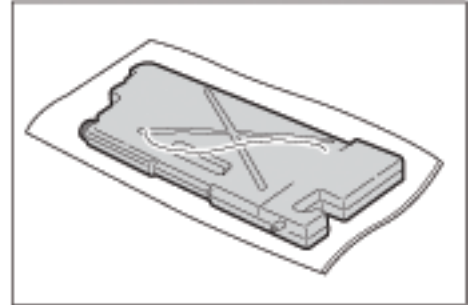

6. Hold the center part on the top of a new container and insert it until it comes to a stop.



7. Close the waste toner container cover.

8. Close the front cover.

How to Clear Paper Jam From Document Feeder (Cover)

1. Grip the handle of the top cover of the document feeder, and open the top cover until it comes to a stop.

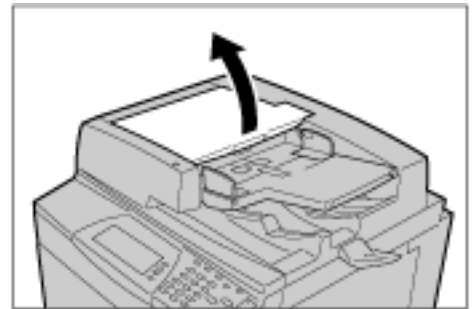

2. Open the left cover until it comes to a stop.

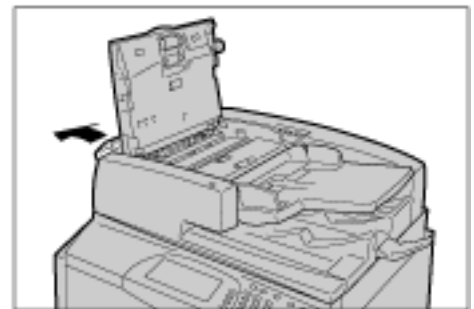

3. If the document is not caught in the entry of the document feeder, pull out the document.



4. If there are instructions to open the inner cover, lift up the lever with the green label on it, and open the inner cover. Then remove the jammed paper.



How to Clear Paper Jam From Document Feeder (Cover)

5. When the inside of the left cover is indicated, remove the jammed document.

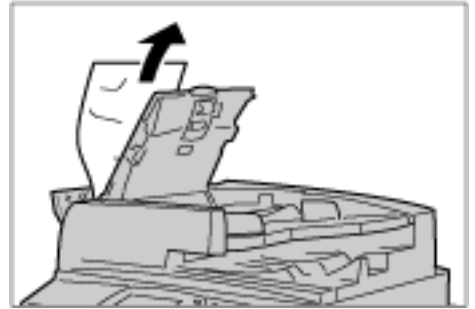

6. Close the top cover of the inner cover until you hear it click into place.
7. Close the left cover of the document feeder until you hear it click into place.
8. Gently return the document feeder tray.

How to Clear Paper Jam From Document Feeder (Cover – For 2 Sided)

1. Open the document cover.

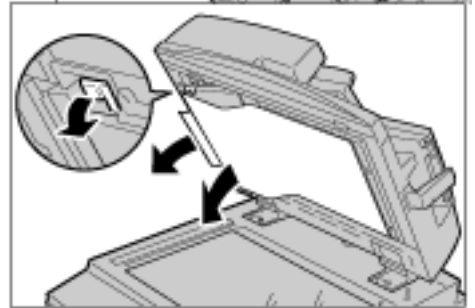

2. Open the belt of the document cover while gripping the lever, and remove the jammed document.

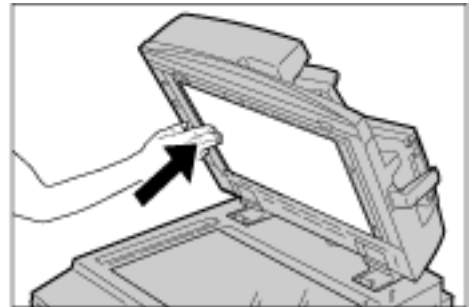

3. Gently return the belt to the original position.

4. Return the document cover to the original position.

How to Clear Paper Jam From Tray 1 and 2

1. Pull out the tray where the paper jam occurred.

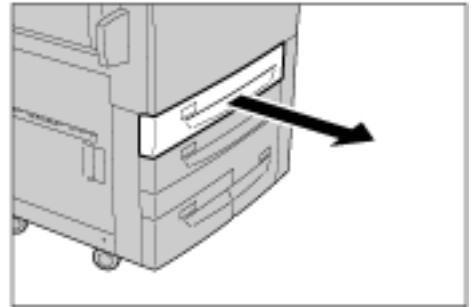

2. Remove the jammed paper.
3. Push the tray in gently until it comes to a stop.

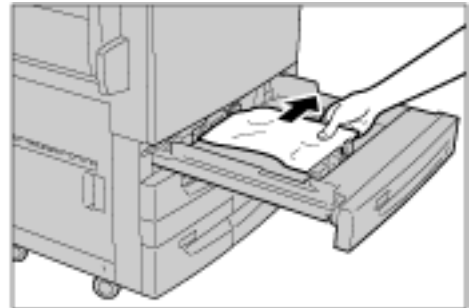

From Tray 3

1. Pull out the Tray 3.

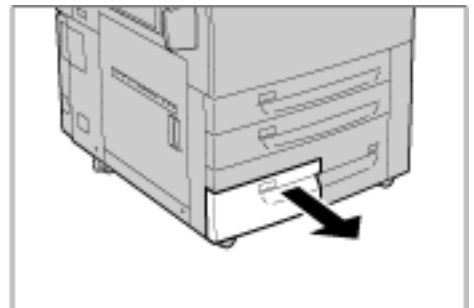

2. Remove the jammed paper.
3. Push the tray in gently until it comes to a stop.

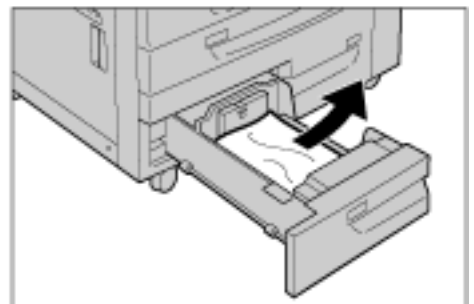

How to Clear Paper Jam From Tray 4

1. Pull out the Tray 4.

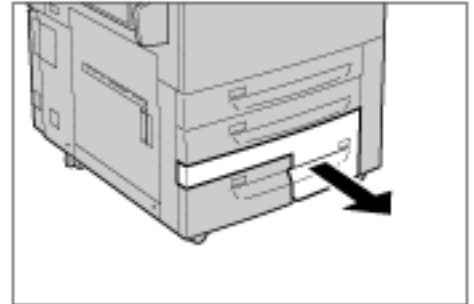

2. Remove the jammed paper.

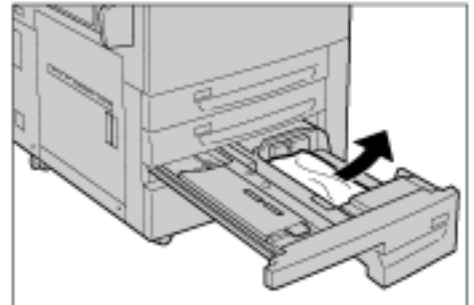

3. If paper is jammed in the paper feed section, open the inner cover and remove the paper.

4. Push the tray in gently until it comes to a stop.

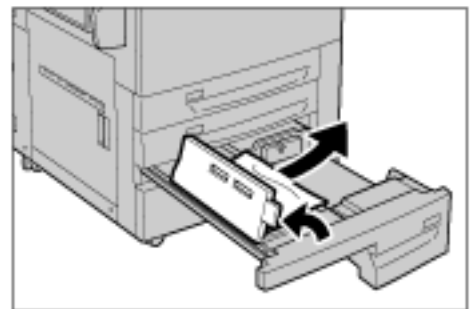

How to Clear Paper Jam From Tray 5

1. Open the Tray 5 (bypass) top cover to remove the jammed paper.

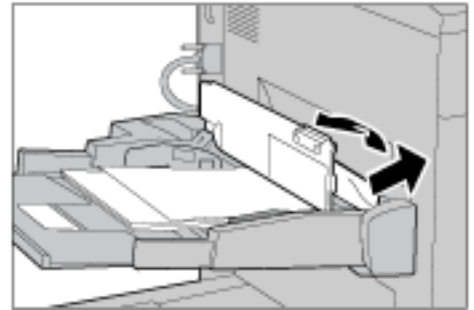

2. Remove all paper loaded in the Tray 5 (bypass).



3. Close the top cover.

4. Fan the paper you removed making sure that all four corners are neatly aligned.

5. Insert the paper into the tray with the printing side facing up until its leading edge lightly comes up against the paper feed entrance.

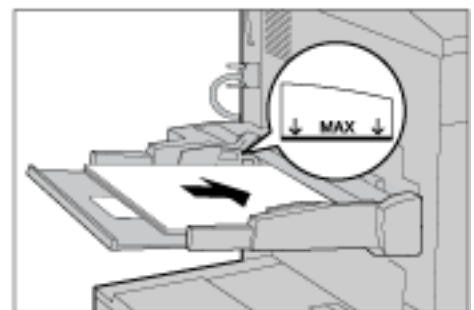

How to Clear Paper Jam From Transfer Module

1. Make sure that the machine has stopped before opening the front cover.



2. Turn the green lever 2 at the center of the transfer module to the right until it is in the horizontal position and then pull the transfer module out to the end.

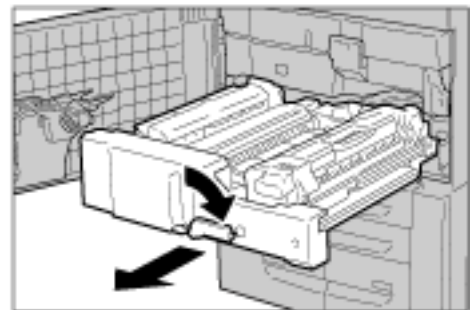

3. Remove the visible jammed paper.



4. Move lever 2a to the right and remove the jammed paper.

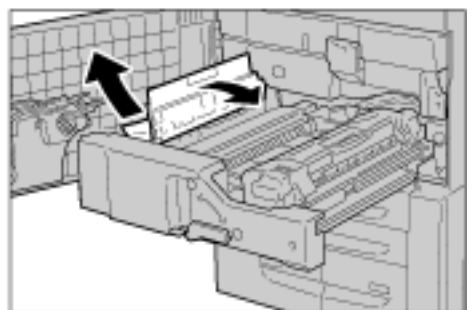

5. Return the lever 2a and 2b to the original position.
6. Insert the transfer module completely and turn the green lever 2 to the left.
7. Close the front cover.

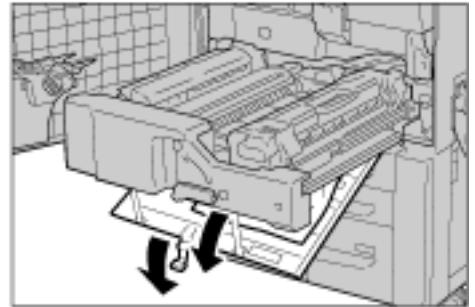

From Bottom Left Cover

1. Open the bottom left cover while gripping the release lever.
2. Remove the upper jammed paper.
3. Remove the lower jammed paper.
4. Close the bottom left cover.

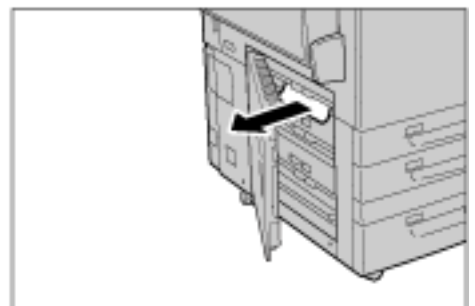
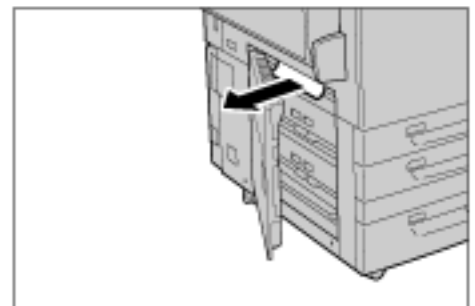
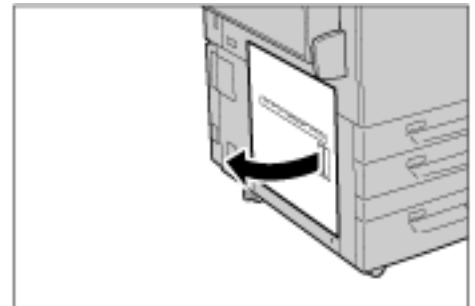

How to Clear Paper Jam From Bottom Right Cover

1. If the finisher is installed, open the front cover of the finisher and then pull down the lever 1a.

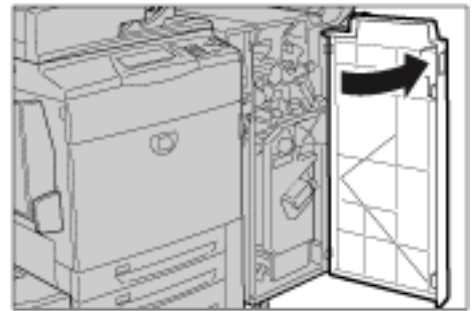

2. Open the bottom right cover while pressing the downward arrow button.

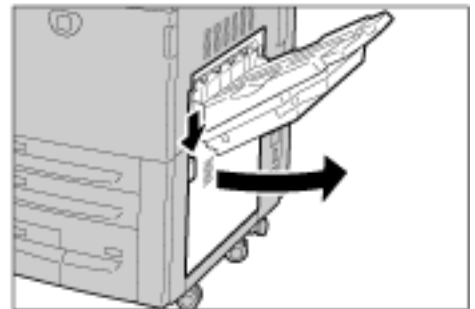

3. Remove the upper jammed paper.

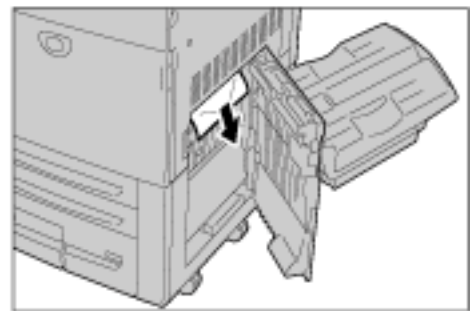

4. Remove the lower jammed paper.

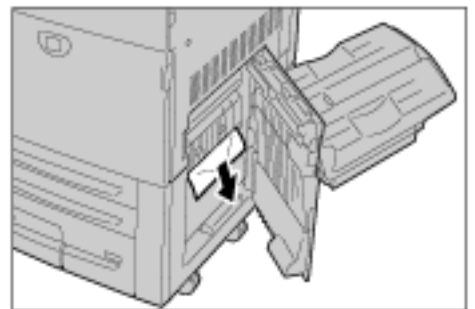

5. Check the lower parts of the machine. If there is jammed paper, remove it.

6. Close the bottom right cover.

7. If the finisher is installed, return the lever 1a to the original position and then close the front cover of the finisher.

How to Clear Paper Jam From Output Tray

1. Remove jammed paper from the output tray.

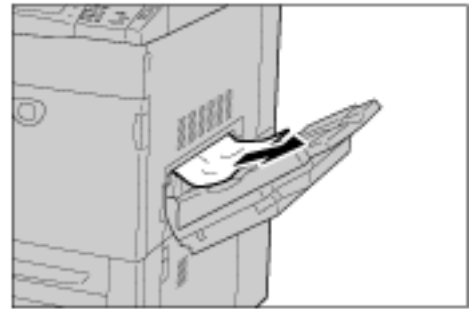

eSUPPORT erox

Online Support Assistant

1 Log onto
www.fujixerox.com.my
 & Select Online Support Assistant



Select product **2**



3 Type a problem & search

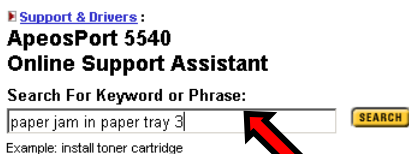

To find a specific fault code, try our [Fault Code Search](#).
 For further help, try our [Tips on Searching](#).
 Use the "How To" and "Solutions For" links on the navigation bar for a quick reference.

Product Family FAQs

- How To Print a System Settings (Configuration Report)
- How To Scan to Email
- How To Scan to Mailbox

You've got the solution ! **4**

Support & Drivers : ApeosPort 5540 :

[Print this page](#) [Email this page](#)

Solution: Remove the Paper Jam in Paper Tray 3

NOTE: Paper can sometimes be torn and remain inside the machine if the paper tray is opened without checking the paper jam position. This may cause machine malfunction. Check where the paper jam occurred before clearing the problem.

- Open Paper Tray 3.



- Remove any jammed paper.
- Push the tray in gently until it comes to a stop.

5 Feedback from you !
 Select Contact Xerox Support
 if you can't find a solution- you
 can report your problem online

Solution Options

Have you found what you are looking for?

Yes	Not Yet	Please Help
I Found My Answer	Return to Solutions List	Contact Xerox Support
Save Page URL	Return to Search Results	
Start a New Search	New Search - Tips on Searching	

[Print this page](#) [Email this page](#)



Online Service & Support Request

1

Log onto

www.fujixerox.com.my

& Select Service & Support Request

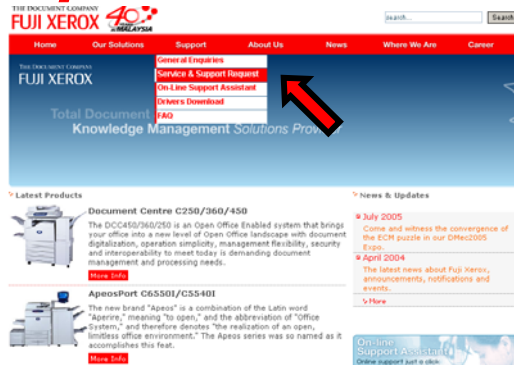

2

Input the machine's info

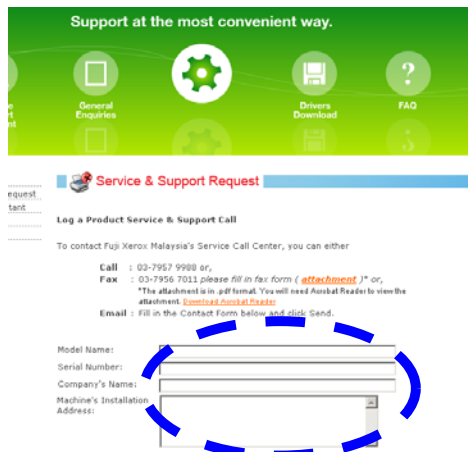

3

Submit your request-
You've done it !!

Problem Description
Please provide as much details as possible about the problem you are experiencing with your product. This will assist our service staff in helping you more quickly.

Problem Description:

Important Note: If you do not receive any feedback from us within 30 minutes, * please log in again.
* Applies during office hour : 8.30a.m - 5.05p.m

Another service to bring us closer to you

Upon receiving your request by FXM Call Center, the request will be logged into our system and you will be notified through e-mail with a report number.

Benefits :

1. No phone call is require
2. No more waiting/holding on the phone line
3. Your call will be logged into our service system on time



Fuji Xerox Asia Pacific Pte. Ltd.

Call Center Manager

SAFETY NOTE

ITEM	DO	DON'T
1.Sharing of Supply socket	One socket for one plug	Do not share socket with heavy load unit. Do not use cable extension/multiple socket extension.
2.Power cord length	Proper length to allow certain loosening	Do not allow cable pull to tension
3.Power cord routing		Avoid obstruction. Keep away from combustable/water/ twisting around table& chair
4.Power cord surface condition		Discard if surface found stripped /exposed/cracked/burnt
5.Ground/Earthing		Do not use 2-pin plug type without grounding wire
6.Condition of Plug/socket		Discard if found cracked/ discolored/deterioration/defor med
7.Plug/socket contact	Ensure plug & socket are tightly connected.	