

QUICK GUIDE

DC 450i /550i



Online Support: www.fujixerox.com.my/support

Website : <http://www.fujixerox.com.my>

INTRODUCTION

The main objective of compiling this Quick Guide is to serve as an easy reference to customers. We understand customers are tight up with daily schedules and can only learn up limited machine feature in the training sessions. Thus, we hope this Quick Guide will provide you with all the essential feature should you encounter any operation problems with the machine.

Kindly contact the following number :

For General Service & Supplies
Toll Free : 1-300-88-1163

Or

To contact us kindly email to us at:

mysallcto@mys.fujixerox.com

TABLE OF CONTENTS

Section A: Copy Features

1. 2-Sided Copy
2. IC Copy – 2 Methods
3. Reduce / Enlarge
4. Finishing
5. Edge Erase
6. Image Shift.
7. Book Copying
8. Multi-Up.
9. Booklet Creation
10. Repeat Image + Original Size

Section B : Fax Feature

Section C : Scan to FTP / SMB Feature

Section D : Scan to Mailbox Feature

Section E : Printing Features

Section F : Maintenance

1. Checking Billing Meter
2. Checking Consumables Status
3. Replacing Toner Cartridge
4. Replacing Waste Toner Container
5. Clearing Paper Jams

Online Service & Support Request

Online Support Assistant

Section A: COPY

2-Sided Copying

Steps: 1. Load document on feeder

2. Goto [Scan Options Tab]

3. Select required options:

1→ 1 Sided

Makes a copy of a 1 sided document on one side of the paper.

1→ 2 Sided

Makes a copy of a 1 sided document on both sides of the paper.

2→ 2 Sided

Makes a copy of a 2 sided document on both sides of the paper.

2→ 1 Sided

Makes a copy of a 2 sided document on one side of the paper.

4. Press Start

IC Copy – 2 methods

I.) Copy IC both sides on the same page

1. Goto [Basic Copying Tab] – Select A4 Paper (Portrait) – Press Save
2. Goto [Image Quality Tab] – Select Original Type: Text/Photograph – Press Save
3. Put IC onto platen glass (Top Left corner) and press Start
4. Take the printed copy and load it to Tray 5 (Bypass)
(Note: Do not change paper order)
5. Open the Cover and Flip IC to the opposite point of A4, press Start

II.) Copy IC both sides front and back page

1. Goto [Basic Copying Tab] – Select A4 Paper (Portrait) – Press Save
2. Goto [Image Quality Tab] – Select Original Type: Text/Photograph – Press Save
3. Goto [Scan Options Tab] – Select 2 Sided – Change to 1 → 2 – Press Save
4. Load the first side of your IC onto platen glass (Top Left corner) and press Start
5. Open the Cover and Flip IC to the opposite point of A4, press Start

Reduce/ Enlarge

(Allows to select/specify the reduction/enlargement ratio within range of 25 - 400%)

- Steps:
1. Load document on feeder
 2. Goto [Basic Copying Tab]
 3. Select Reduce / Enlarge
 4. Select copy ratio
 5. Select Save
 6. Press Start

“ 100%

Copies are made at the same size as the original document.

“ Auto%

The copy ratio is automatically set based upon the document and paper sizes, and the document is copied to fit in the selected paper.

“ Presets % (7 Types)

Select from among 7 preset ratios.

“ Variable %

You can enter any ratio for copying. Set the ratio within the range from 25 to 400% in 1% increments.

Finishing

(Allows to sort copy outputs collated or uncollated)

- Steps:
1. Load document on feeder
 2. Goto [Output Format Tab]
 3. Select Finishing
 4. Select required options
 5. Select Save
 6. Press Start

“ Auto

Copies are output collated

“ Collated / Stapling / Punching

The machine can output sheets sorted into sets that are arranged in page order.

“ Uncollated

The machine can output the specified number of copies and sort sheets by page

Edge Erase

(To erase shadows/unwanted marks e.g. hole punch from edges or centre of page)

- Steps:
1. Load document on feeder
 2. Goto [Scan Options Tab]
 3. Select Edge Erase
 4. Change the default from Normal to Edge Erase
 5. Use the arrow up or down button to set the amount of area to be erased
 6. Select Save
 7. Press Start

Image Shift

(Allows to change the position of the image on an output page)

- Steps:
1. Load document on feeder
 2. Goto [Scan Options Tab]
 3. Select Image Shift/Variable Shift
 4. Select any items for image shift options
 - Auto Center; Corner Shift or Variable Shift
 5. Select Save twice
 6. Press Save

Bound Original

(To copy bound documents using document glass into 2 separate pages)

- Steps:
1. Open and place book at top left on the platen glass
 2. Goto [Scan Option Tab]
 3. Select Book Copying
 4. Select required option
 - Left Page then Right OR Right Page then Left
 5. Select Save
 6. Press Start

Multiple-up

(To copy 2, 4 or 8 documents onto 1 sheet of paper. Document Centre will automatically reduce/enlarge the images)

- Steps:
1. Load document on feeder
 2. Goto [Output Format Tab]
 3. Select Multiple-Up
 4. Select 2up, 4up or 8up
 5. Select required Image Order
 6. Select Save
 7. Press Start

Booklet Creation

(To print the images side by side on both sides of each pages in the correct order to make a booklet. Fold the copies in half and staple in the middle to create a finished booklet)

- Steps:
1. Load document on feeder
 2. Goto [Output Format Tab]
 3. Select Booklet Creation
 4. Select Left Bind/ Top Bind or Right Bind
 5. Select Save
 6. Goto [Basic Copying Tab]
 7. Select paper tray that contains of Landscape paper
 9. Press Start

Repeat Image + Original Size

(Print original image repeatedly on one sheet of paper)

- Steps:
1. Load document on platen glass
 2. Goto [Output Format Tab]
 3. Select Repeat Image
 4. Select Auto Repeat
 5. Select Save
 6. Goto [Scan Options Tab]
 7. Select Originals Size
 8. Set document size using left-right for value "X" and top-bottom for value "Y"
 9. Select Save
 10. Press Start

Section B: FAX

Keypad Dialing

(Direct Dialing using numeric Keypads)

- Steps:
1. Load document(s) onto the Document Feeder
 2. Enter fax number using numeric keypad
 3. Press Start

One Touch Dialing

(Using Speed Dial Number for pre-programmed fax number)

- Steps:
1. Load document(s) onto the Document Feeder
 2. Select Speed Dial number using One Touch Keypad
 3. Press Start

Dial Directory

(Search by pre-programmed Recipient's Name from the Address book)

- Steps:
1. Load document(s) onto the Document Feeder
 2. Select Dial Directory
 3. Select Recipient's Name
 4. Press Start

Broadcast Send

(Transmitting fax to multiple destinations)

- Steps:
1. Load document(s) onto the Document Feeder
 2. Enter Fax number using:
 - Numeric keypad
 - One Touch Dial Button
 - Speed dial
 3. Select Next Recipient to add new recipients.
 4. Repeat steps 2 - 3 until all numbers are entered.
 5. Press Start

Note: Max number of recipients specified at one time is as follow:

- using numeric keypad : 200 locations
- using address number : 500 locations
- using numeric keypad + address number : 699 locations.

Programming Fax Address Book (Speed Dial)

- Steps:
1. Select All Services Screen
 2. Select Setup Menu - Select Address Book
 3. Select an Address Number (e.g 001, or 002..[not in use])
 4. Press [Create / Delete]
 5. Select Address Type – Press [Change Settings]
 6. Select Fax option - Press Save
 7. Select item Fax Number - Press [Change Settings]
 8. Enter Fax Number - Press Save
 9. Select item Recipient Name - Press [Change Settings]
 10. Key in Recipient Name - Press Save
 11. Select item Index - Press [Change Settings]
 12. Enter a single alphanumeric character - Press Save
 13. Press Save to save current entry
 14. Repeat Step 3 to Step 13 to add new numbers -or-
Press Close to Exit Setup Address Book

Programming Group Send

(Max 50 Groups containing 20 addresses can be registered)

- Steps:
1. Select All Services Screen
 2. Select Setup Menu - Select Group Send
 3. Select a Group Number (e.g. #01; #02..)
 4. Press [Create/Delete]
 5. Use numeric keypad to enter the 3-digit Address number (e.g 001) and Press [Add]
 6. Repeat Steps to continue registering fax number into the group
 7. Press Save to Exit Setup Group Send Menu

Transmission Report

(To activate transmission report option in order to print a delivered/undelivered report after transmission)

- Steps:
1. Load document(s) onto the Document Feeder
 2. Enter fax number
 3. Go to Send Option Tab - Select Transmission Report
 4. Select On and press Save
 5. Press Start

* A transmission report is automatically printed when the transmission completes.

2-sided Originals

(transmitting both sides of documents automatically)

- Steps:
1. Load document(s) onto the Document Feeder
 2. Enter fax number
 3. On the Basic Features Tab - Select 2-sided Originals
 4. Select the required option (H to H / H to T)
 5. Press Save
 6. Press Start

On-Hook Dialing

(Use this feature when using Manual Send or for troubleshooting line)

- Steps:
1. Load document(s) onto the Document Feeder
 2. Enter fax number
 3. On the On-Hook/Others Tab
 4. Select On-Hook (Manual Send/Receive) button
 5. Enter Fax Number and wait for connection.
 6. Press Start button once connected to transmit fax..
 7. Press Exit (Line Cut) button to hang up

How to Cancel A Fax Job

- Steps:
1. On the Control Panel of the machine
 2. Press [Job Status] Button
 3. Select the fax job to be cancel
 4. Press Stop button on the touch screen
 5. Press Exit

Section C: SCAN TO PC (FTP/SMB)

Scan to PC (FTP/SMB) – From Address Book

- Steps:
1. Press All Services button
 2. Select Scan to FTP/SMB
 3. Select Address Book
 4. Select Recipient Name
 5. Select Save
 6. Under [Basic Scanning Tab], select File Format
 7. Goto [Output Format Tab]
 8. Select File Name (example: PDF)
 9. Key in File Name
 10. Select Save
 11. Press Start

Section D: SCAN TO MAILBOX

Scan to Mailbox

(This feature scan and save document(s) on the machine mailbox an import/retrieve scanned documents using specific program.)

- Steps:
1. Press All Services button
 2. Select Scan to Mailbox
 3. Select your own Mailbox Number
 4. Goto [Scan Options Tab] to change optional settings:
 - Select 2 sided originals (Head to Head)
 - Select Scan Size
 - Select Reduce/Enlarge
 5. Goto [Output Format Tab]
 6. Select Document Name
 7. Key in Document Name
 8. Select Save
 9. Press Start

Retrieving / Importing Scanned Documents

- Steps:
1. Go to START > PROGRAMS > FUJI XEROX > UTILITY > MAILBOX VIEWER2
 2. Identify the scanner (by printer name) and press Select Scanner button
 3. Enter your Mailbox Number into the text box (e.g. 1)
 4. Enter your 4-digit password (if any)
 5. Click on Open Mailbox button
 6. Click 'Import' to import the scanned file
 7. Select Close button once completed file transfer
 8. By default the Scanned documents are stored in *My Documents folder, Fuji Xerox, Network Scan*

Section E: PRINTING

Printing Job Types

Main Features

1. Normal Print
To print documents from your PC as a normal print job
2. Secure Print
Allows you to set user ID and password for the document on your PC. When send for printing, it temporary stores the documents on the machine and only prints out when you select your user ID and password on the physical machine
3. Sample Print
Before printing multiple sets of a document, you may print one sample set for trial before proceeding the next sets
4. Delay Print
Allows you to print your documents at a specific time

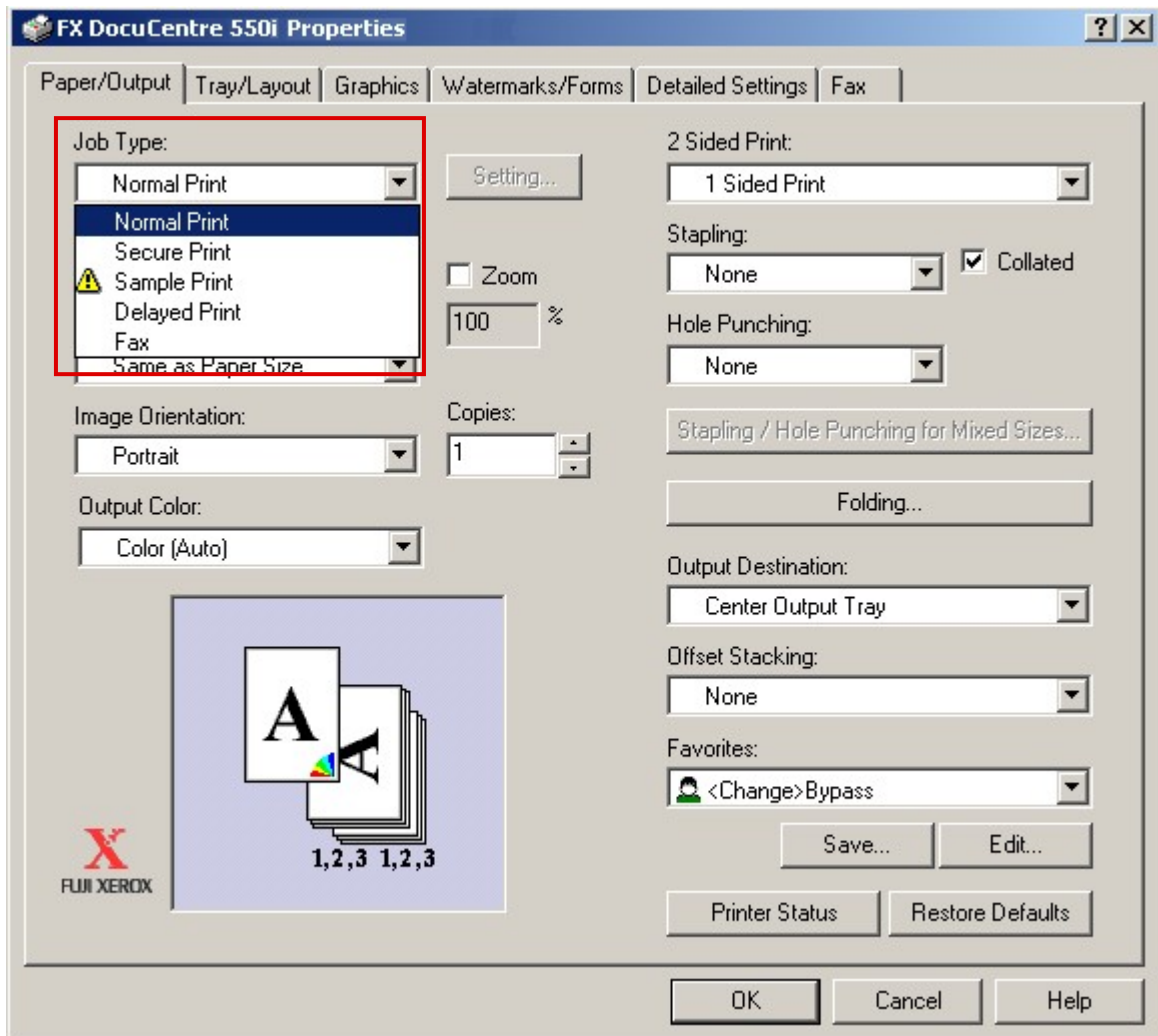

Normal Print

- Steps :
1. Go to File, Select Print
 2. Select Printing Preferences
 3. Under Job Type, Select Normal Print
 4. Select OK

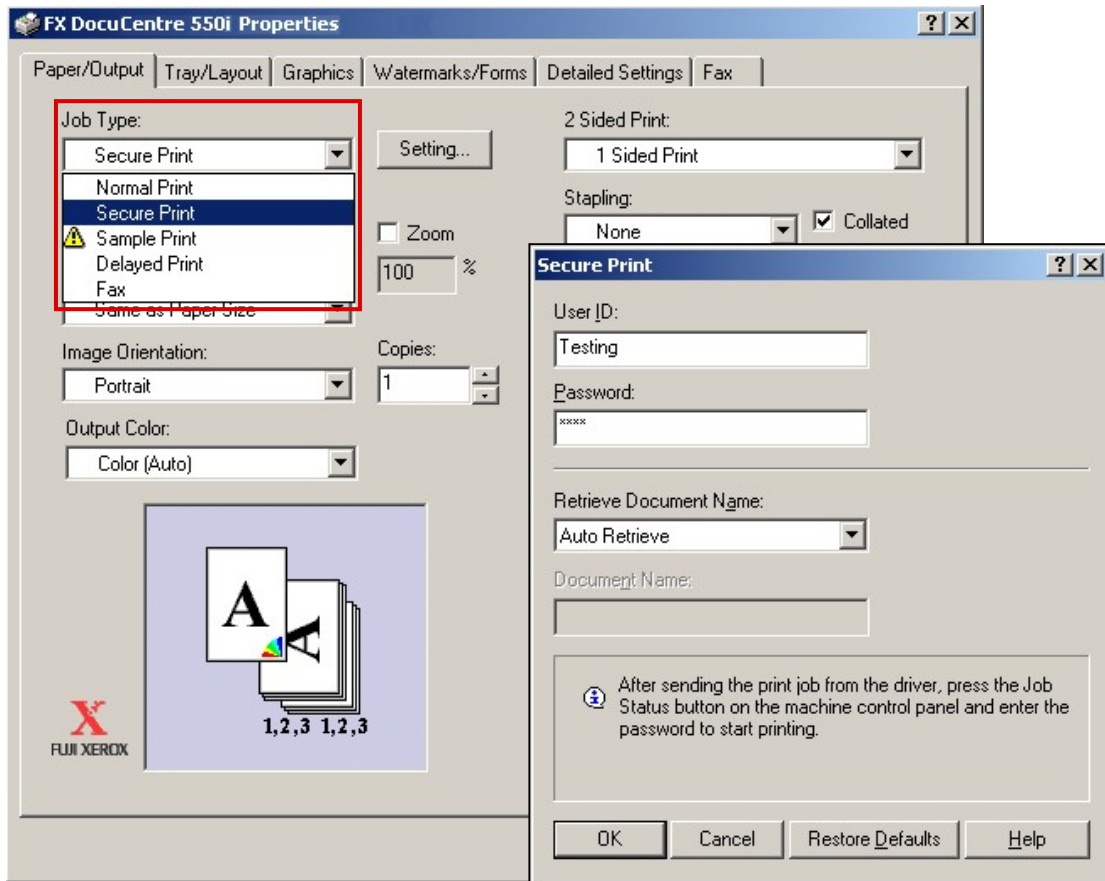

Secure Print

- Steps :
1. Go to File, Select Print
 2. Select Printing Preferences
 3. Under Job Type, Select Secure Print
 4. Under Secure Print Message Box, key in:-
 - User ID
 - Password
 - Document Name

Secure Print (Document Retrieval)

- Steps:
1. Select Job Status Button (at the machine)
 2. Click Stored Documents
 3. Select User ID
 4. Select Document List
 5. Key-in Password and Confirm
 6. Select Job and Print

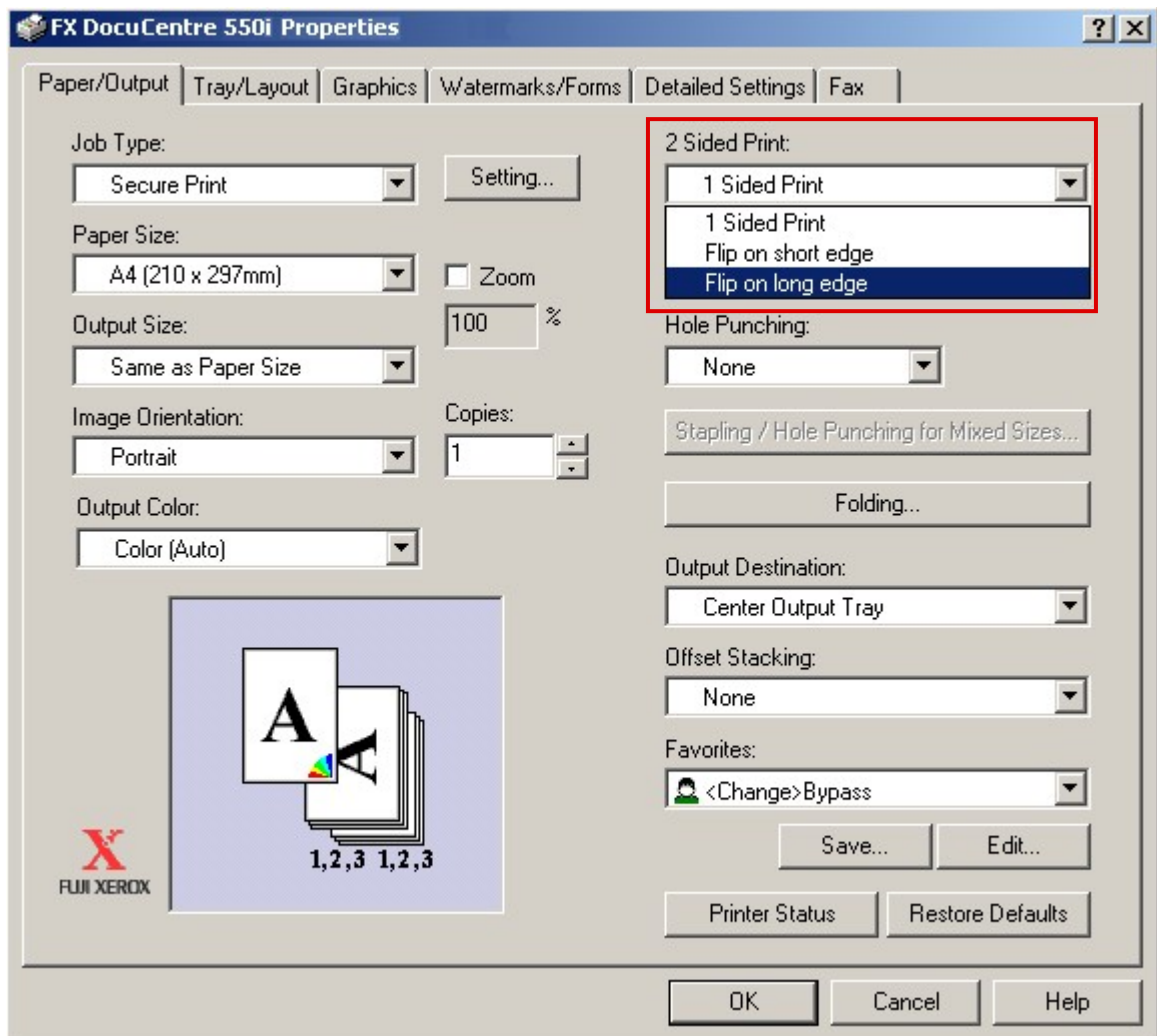

2-sided Print

- Steps :
1. Go to File, Select Print
 2. Select Printing Preferences
 3. Under 2 Sided Print, Select Flip on Long Edge or Short Edge
 4. Select OK

Note: Flip on Long Edge is known as Head to Head
 Flip on Short Edge is known as Head to Toe

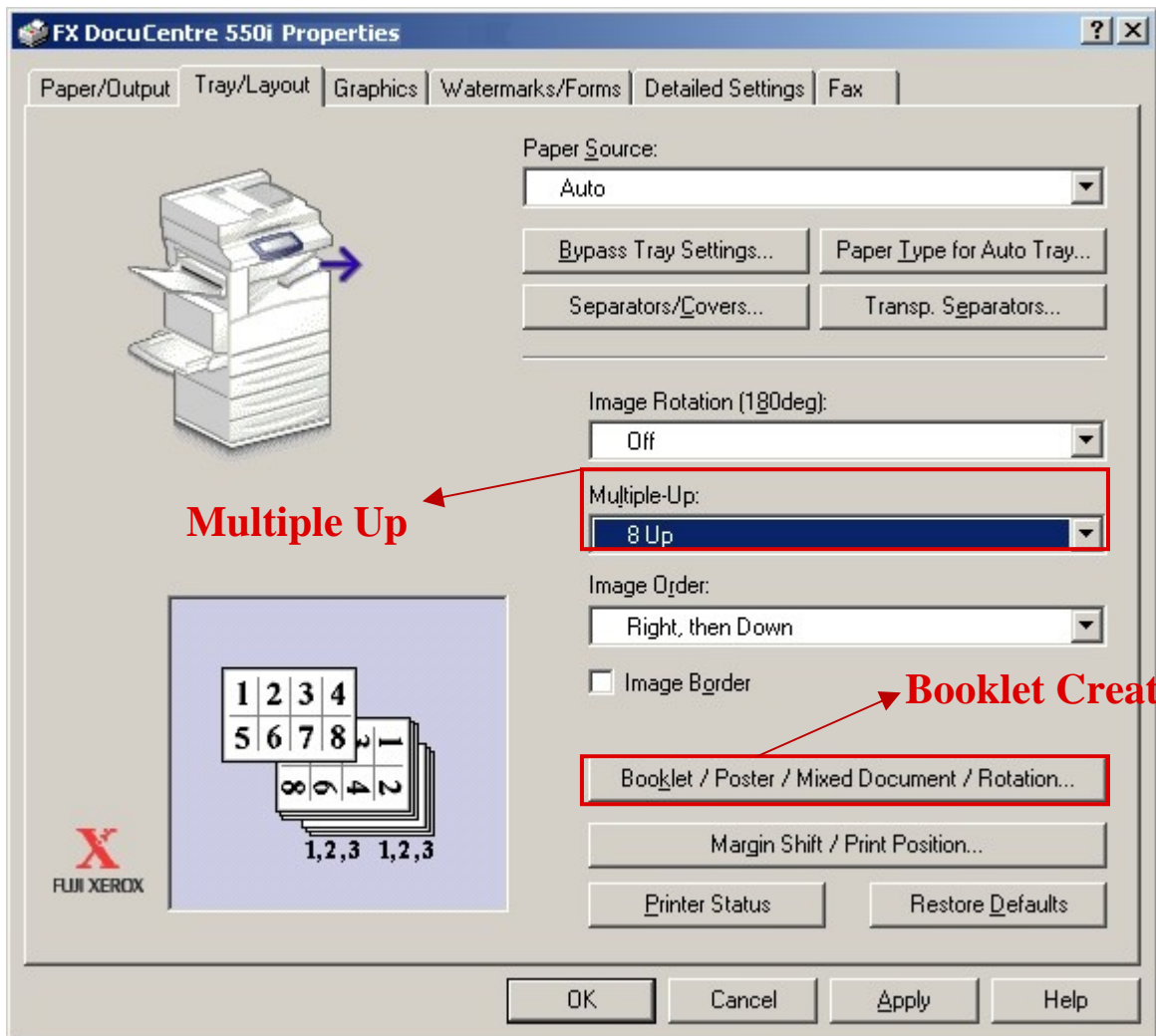

Multi-Up

- Steps :
1. Go to File, Select Print
 2. Select Printing Preferences
 3. Goto [Tray/Layout Tab]
 4. Select Multiple-Up (1Up to 32 Up)
 5. Select OK

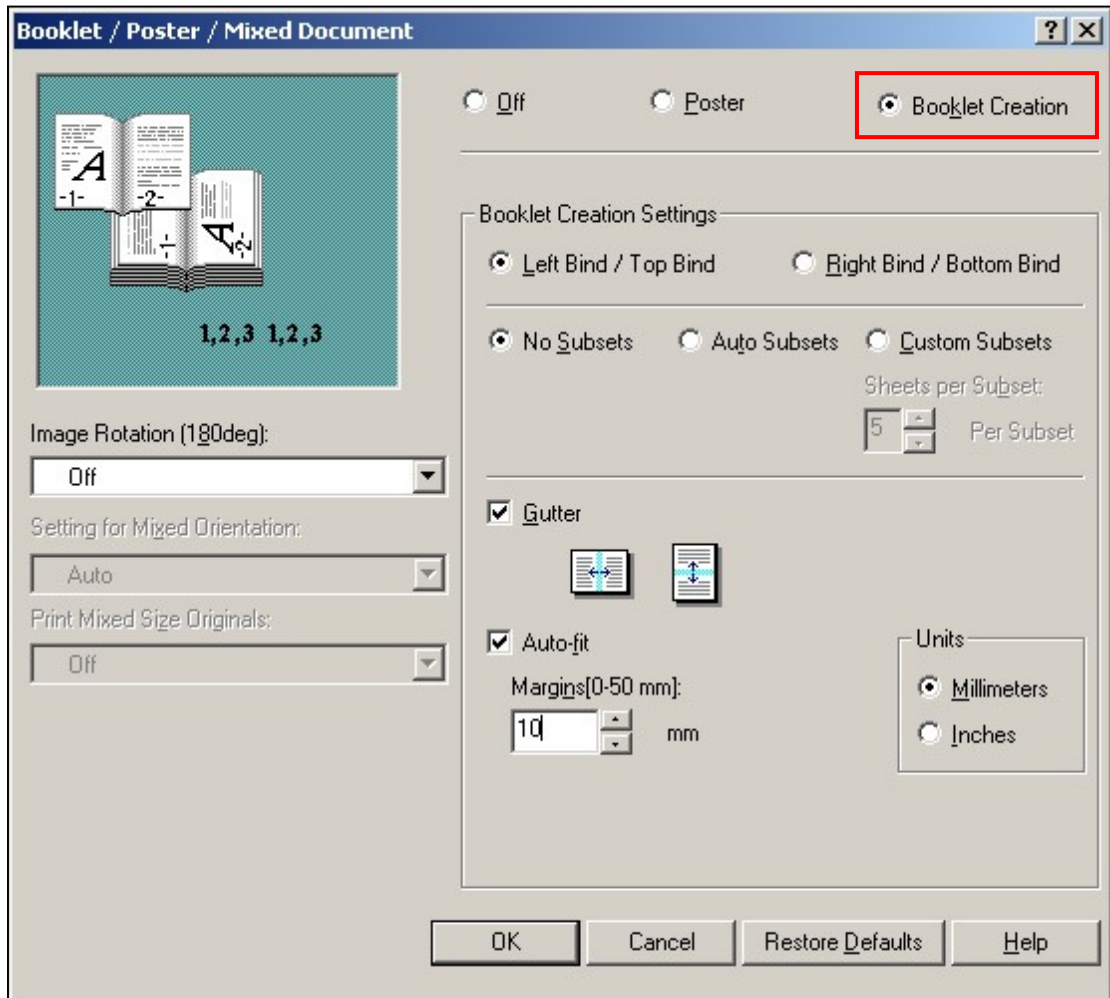

Booklet Printing

- Steps :
1. Go to File, Select Print
 2. Select Printing Preferences
 3. Goto [Tray/Layout Tab]
 4. Select Booklet/ Poster/ Mix Document/ Rotation
 5. Select Booklet Creation Option Button
 6. Select OK to the pop-up message box
 7. Select OK

PC Faxing

1. On your document, Select File Menu - Select Print
2. Select printer - Select printing Properties
3. On the Jobs Type list – Select FAX
4. Click OK on all open windows
5. The Fax Recipient dialog box appear.

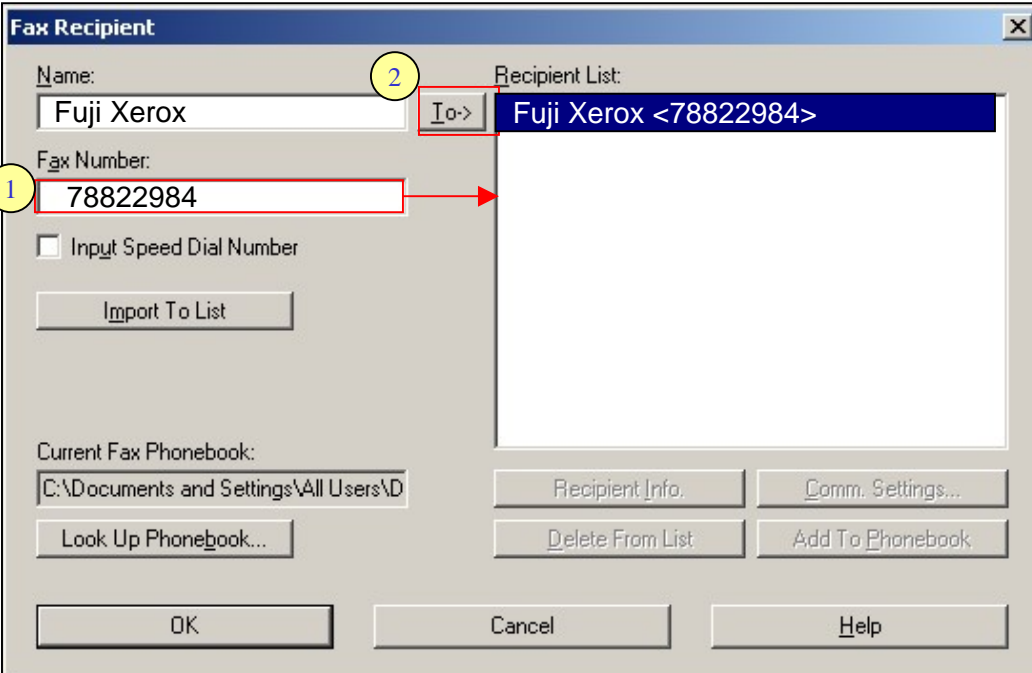
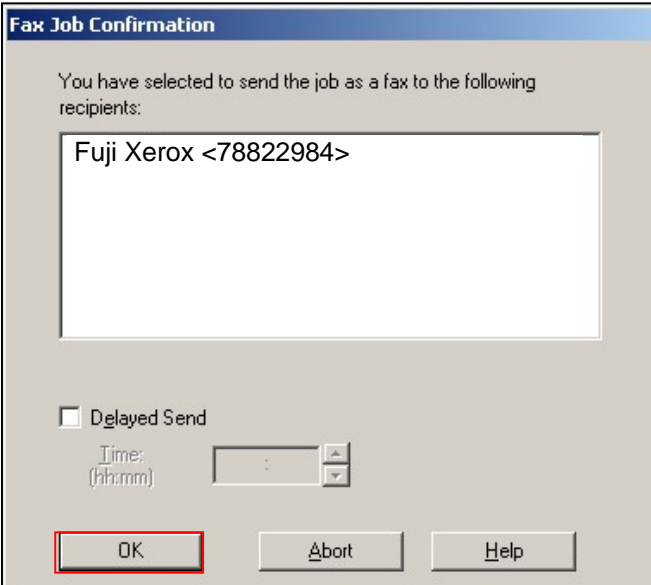
6. Enter Recipient Name and Fax Number into the respective field
7. Press "To->" button.
9. Repeat step 8 & step 9 to add more recipients
10. Press OK
11. On the Fax Job Confirmation box, check Delayed Send (if necessary) or Click OK to proceed.

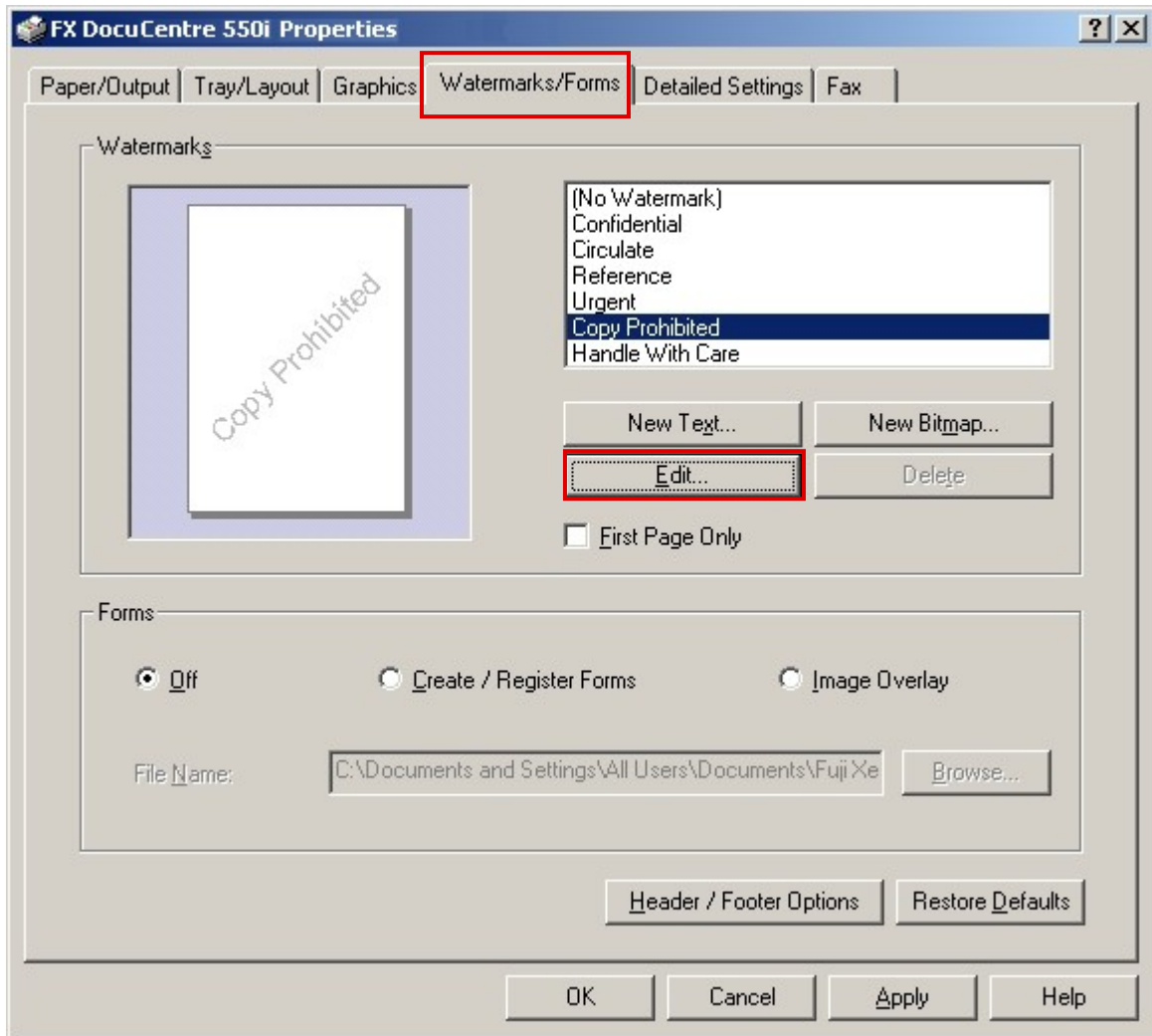

Watermarks

1. Go to File Menu of your document - Select Print
2. Select Printer
3. Select Printing Properties
4. Select Watermarks/Forms tab
5. Select Required Watermark (e.g Confidential / Copy Prohibited)
Or Click New Text to enter user defined text as required.
6. Click OK on all open windows

Section F: Maintenance

Checking Billing Meter

1. Press <Machine Status> button on the control panel.
2. Select Billing Meter/Print Report Tab
3. Select Billing Meter
4. Press Close button once done

Notes:

Serial Number – Displays the serial number of the machine

Meter 1 – Total Meter 2 + Meter 3 + Meter 4

Meter 2 – Number of copies

Meter 3 – Number of prints

Meter 4 – Number of fax

Checking Consumables

You can check the status of consumables in the [Consumables] screen. The status of consumables is shown as "Ready", "Replace Soon", or "Replace Now". For toner, the amount is shown in percentage (0 to 100%).

- Steps:
1. Press <Machine Status> button on the control panel
 2. Select Consumables Tab
 3. Press Close button once done

*Consumables Status Reminder:

REPLACE SOON: To Order New Cartridges

REPLACE NOW: To Replace Immediately and Place New Order for Standby

Replacing Drum Cartridge

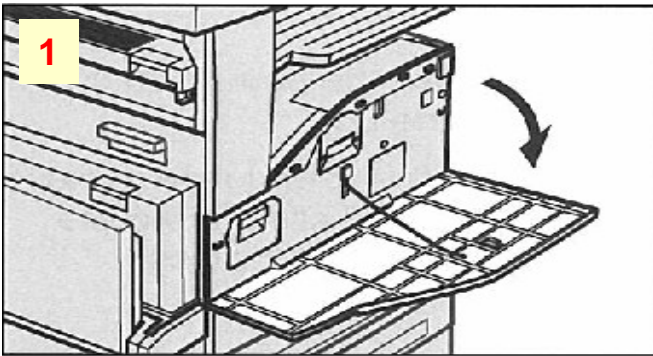

Open the front cover of the machine

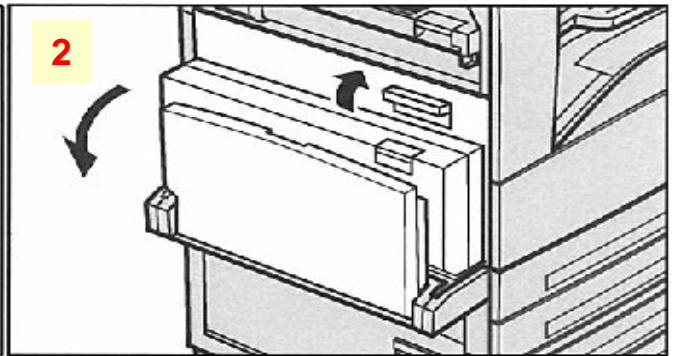

Lift lever to open Cover A

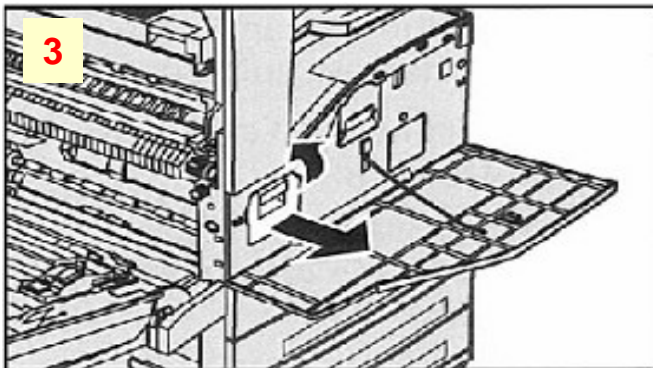

Lift orange lever. Slide out the drum cartridge slowly. Hold orange handle and remove the cartridge from machine.

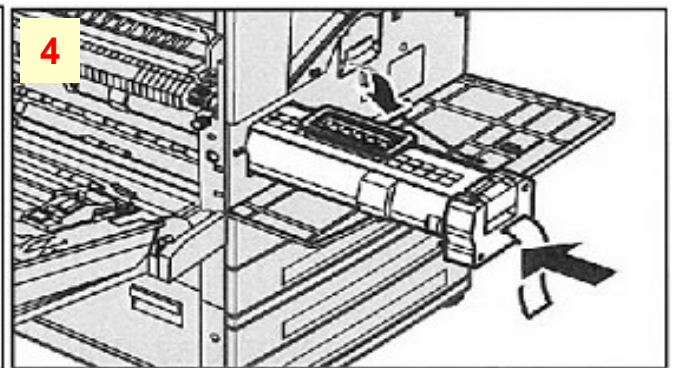

Remove new cartridge from the box. Place cartridge straight in position as shown. Slide it into the slot until it clicks.

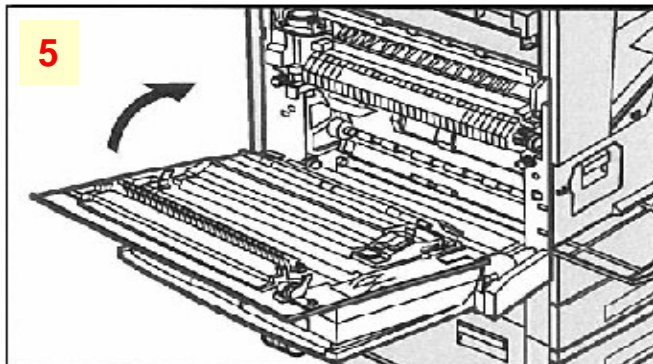

Close Cover A until it latches.

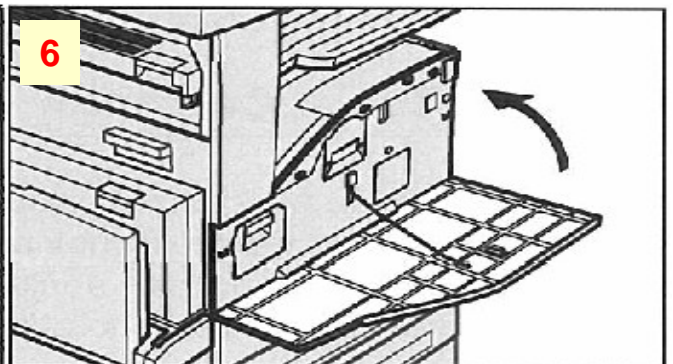

Close front cover.

Replacing Toner Cartridge

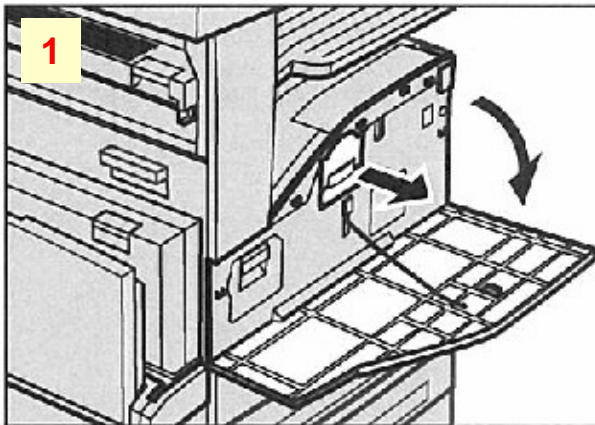

Open the front cover of the machine

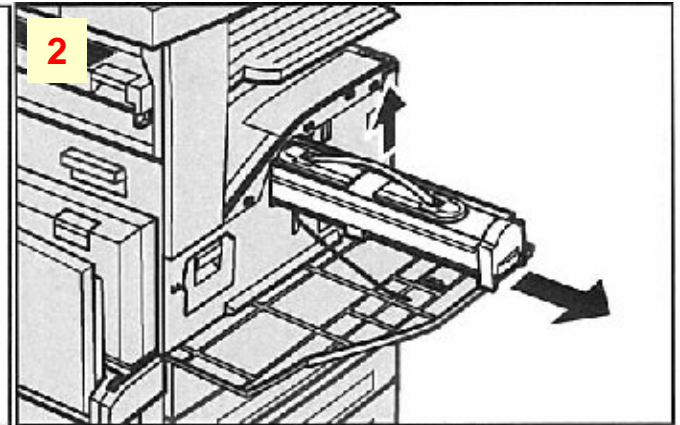

Pull the toner cartridge out until you can lift the handle on top of the cartridge. Hold the handle and remove the cartridge from the machine.

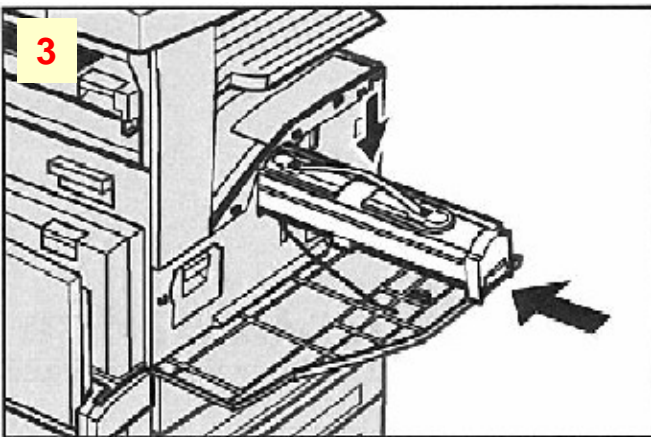

Slide the new toner cartridge into the machine until it clicks

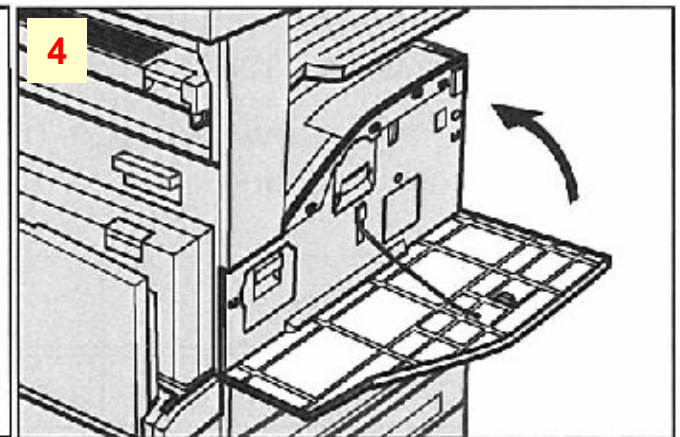

Close the machine front cover.

Clearing Paper Jams

Paper Jams in Cover A

Open Cover A

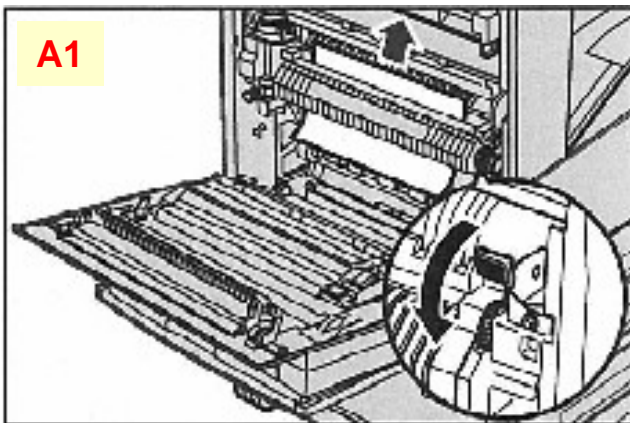

If the jammed paper is inside the fuser unit, rotate the green lever A1 in the direction of the arrow to pull the paper out of the fuser unit from the top.

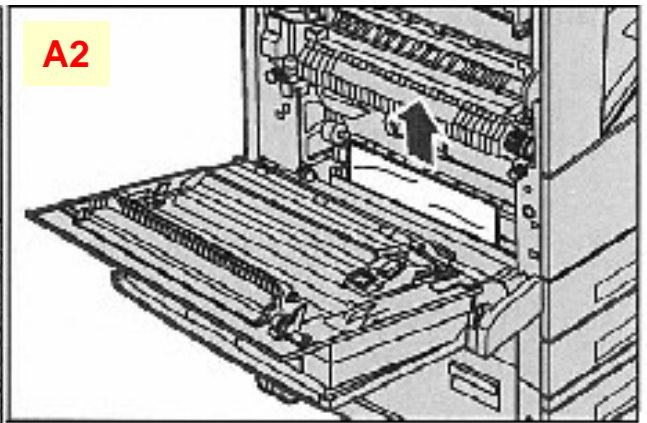

If the edge of the jammed paper does not reach the fuser unit, remove the paper in the direction of the arrow.

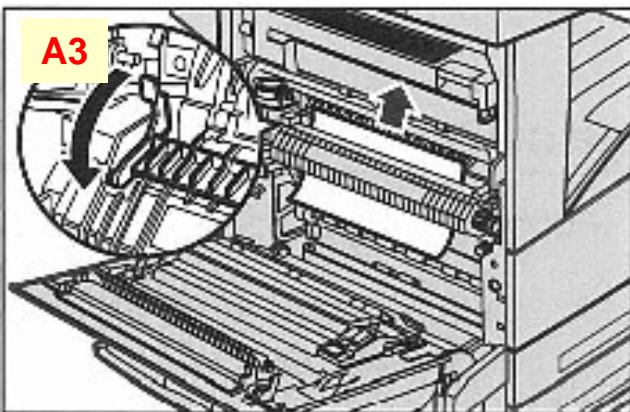

If the jammed paper is inside the fuser unit, rotate the green lever A2 in the direction of the arrow to open the fuser unit cover.

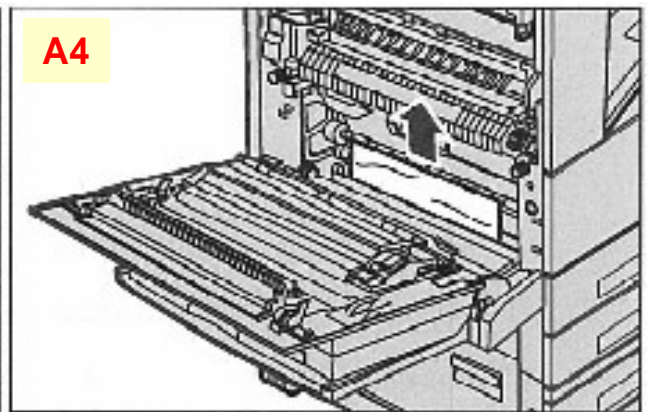

If the jammed paper is found behind the fuser unit, carefully remove it from the machine

Note: Do not touch the fuser unit because it may be hot.

Clearing Paper Jams

Paper Jams in Cover B

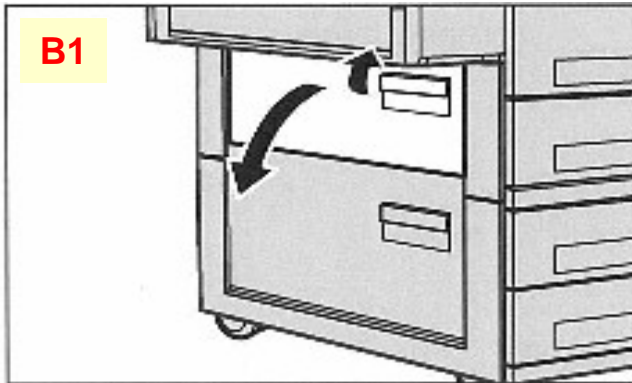

If the jammed paper is inside Cover B open Cover B while lifting up the release lever.

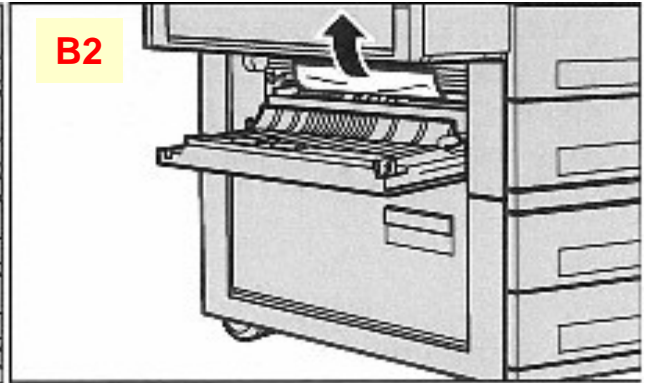

Remove the jammed paper. Close the Cover B until it latches.

Paper Jams in Cover C

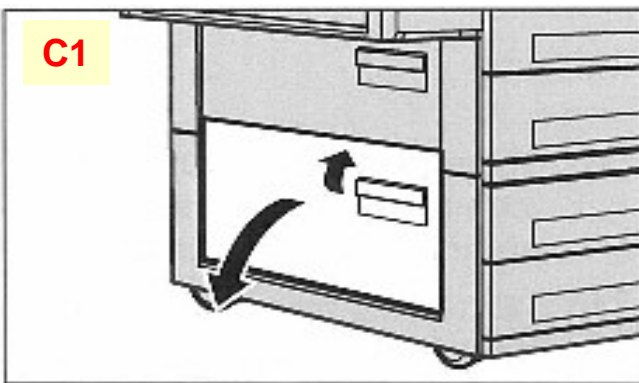

If the jammed paper is inside Cover C open Cover B while lifting up the release lever.

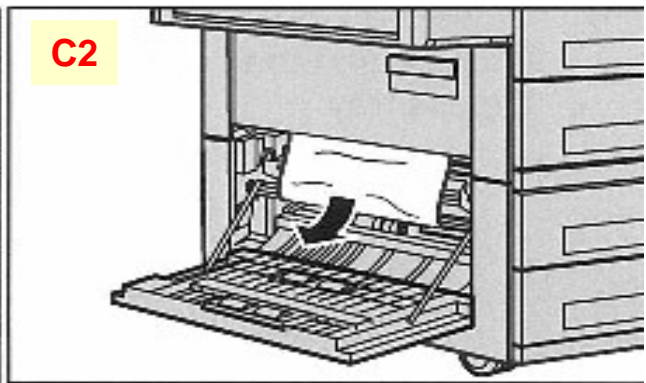

Remove the jammed paper. Close the Cover C until it latches.

Clearing Paper Jams

Paper Jams in Cover D

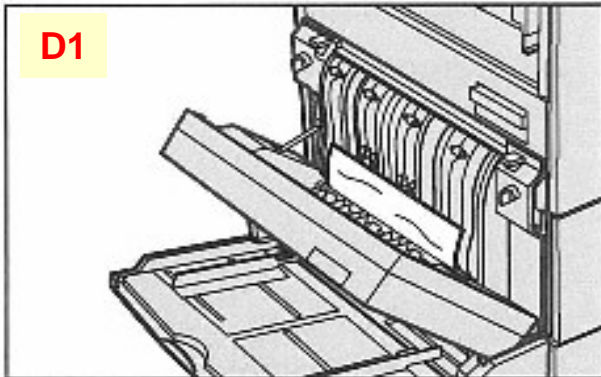

Open the Cover D while lifting up the release lever. Remove jammed paper and close Cover D until latches.

Paper Jams in Cover E

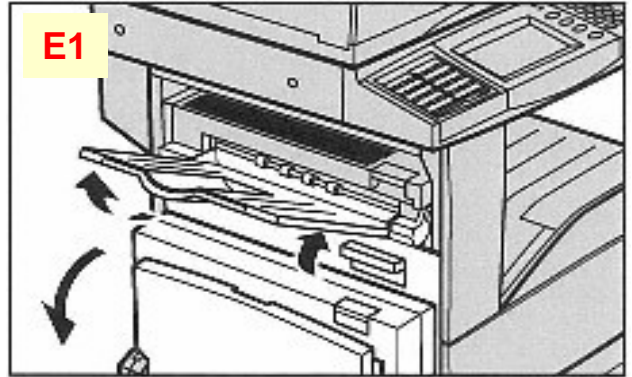

Open the bypass tray, and then open Cover A while lifting up the release Lever.

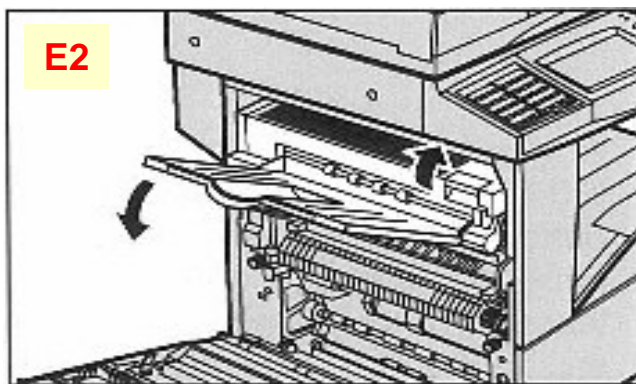

Lift up the handle to open Cover E.

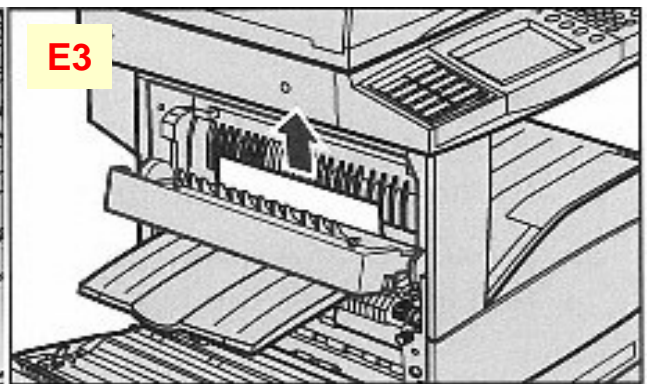

Remove the jammed paper & close Cover E until it latches. Close bypass tray.

Clearing Paper Jams

Document Jams in Document Feeder

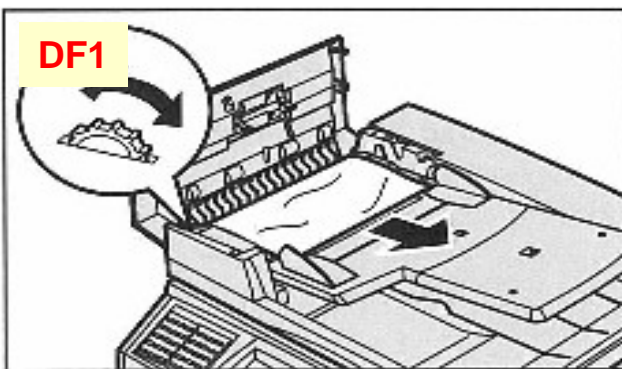

Open the document feeder cover, then remove the jammed document. Turn the green wheel to feed the jammed document out of the document feeder. Close document feeder cover

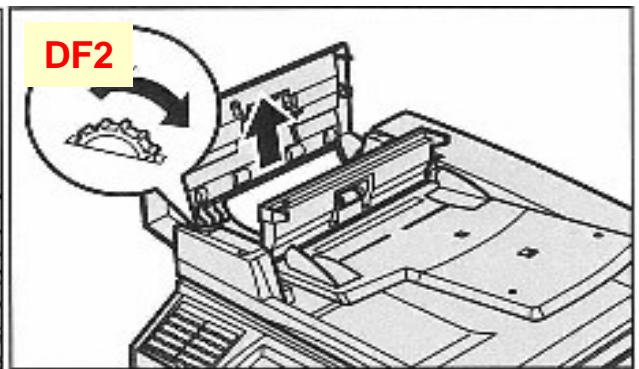

If a 2-sided document is jammed underneath the inner cover, open it and turn the green wheel to remove document. Close inner cover and close document feeder cover.

Paper Jams in the Bypass Tray

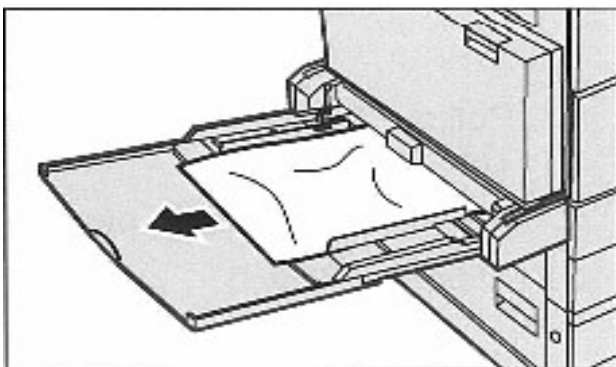

Remove jammed paper in the bypass tray.

Note: Please remove staples & paper clips before inserting paper into the Trays

eSUPPORT

Online Support Assistant



1

Log onto

www.fujixerox.com.my

& Select Online Support Assistant



2

Select product



3

Type a problem & search

Support & Drivers :
ApeosPort 5540
Online Support Assistant

Search For Keyword or Phrase:
 paper jam in paper tray 3

Example: install toner cartridge

To find a specific fault code, try our [Fault Code Search](#).
 For further help, try our [Tips on Searching](#).
 Use the "How To" and "Solutions For" links on the navigation bar for a quick reference.

Product Family FAQs

- How To Print a System Settings (Configuration Report)
- How To Scan to Email
- How To Scan to Mailbox

4

You've got the solution !

Support & Drivers : ApeosPort 5540 :

[Print this page](#) [Email this page](#)

Solution: Remove the Paper Jam in Paper Tray 3

NOTE: Paper can sometimes be torn and remain inside the machine if the paper tray is opened without checking the paper jam position. This may cause machine malfunction. Check where the paper jam occurred before clearing the problem.

- Open Paper Tray 3.



- Remove any jammed paper.
- Push the tray in gently until it comes to a stop.

5

Feedback from you !

Select Xerox Support if you can't find a solution- you can report your problem online

Solution Options

Have you found what you are looking for?

Yes	Not Yet	Please Help
I Found My Answer	Return to Solutions List	Contact Xerox Support
Save Page URL	Return to Search Results	
Start a New Search	New Search - Tips on Searching	

[Print this page](#) [Email this page](#)



FUJI XEROX 40th Anniversary

Home Our Solutions Support About Us News Whom We Are Career

Support at the most convenient way.

On-Line Support Assistant General Enquiries Drivers Download FAQ

Support

General Enquiries Service & Support Request Online Support Assistant Drivers Download FAQs

Service & Support Request

Log a Product Service & Support Call

To contact Fuji Xerox Malaysia's Service Call Center, you can either

Call : 03-7957 9988 or,
 Fax : 03-7956 9022 please fill in the form (attachment) * or,
 *The attachment is in .pdf format. You will need Acrobat Reader to view the attachment. [Download Acrobat Reader](#)

Email : Fill in the Contact Form below and click Send.

Model Name: _____
 Serial Number: _____
 Company's Name: _____
 Machine's Installation Address: _____

Online Service & Support Request

1 Log onto

www.fujixerox.com.my

& Select Service & Support Request

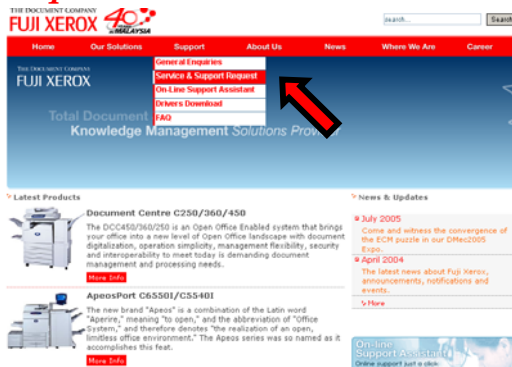

2 Input the machine's info

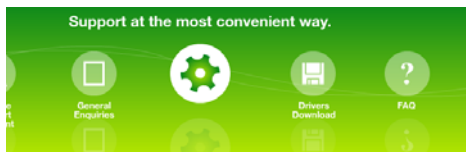

Service & Support Request

Log a Product Service & Support Call

To contact Fuji Xerox Malaysia's Service Call Center, you can either

Call : 03-7957 9988 or,
 Fax : 03-7956 7011 please fill in fax form (**attachment**)* or,
 *The attachment is in .pdf format. You will need Acrobat Reader to view the attachment. [Download Acrobat Reader](#)

Email : Fill in the Contact Form below and click Send.

Model Name:
 Serial Number:
 Company's Name:
 Machine's Installation Address:

3 Submit your request- You've done it !!

Problem Description

Please provide as much details as possible about the problem you are experiencing with your product. This will assist our service staff in helping you more quickly.

Problem Description:

Important Note: If you do not receive any feedback from us within 30 minutes, * please log in again.
 * Applies during office hour : 8.30a.m - 5.05p.m

Another service to bring us closer to you

Upon receiving your request by FXM Call Center, the request will be logged into our system and you will be notified through e-mail with a report number.

Benefits :

1. No phone call is require
2. No more waiting/holding on the phone line
3. Your call will be logged into our service system on time



*Fuji Xerox Asia Pacific Pte. Ltd.
 Call Center Manager*

SAFETY NOTE

ITEM	DO	DON'T
1.Sharing of Supply socket	One socket for one plug	Do not share socket with heavy load unit. Do not use cable extension/multiple socket extension.
2.Power cord length	Proper length to allow certain loosening	Do not allow cable pull to tension
3.Power cord routing		Avoid obstruction. Keep away from combustable/water/ twisting around table& chair
4.Power cord surface condition		Discard if surface found stripped /exposed/cracked/burnt
5.Ground/Earthing		Do not use 2-pin plug type without grounding wire
6.Condition of Plug/socket		Discard if found cracked/ discolored/deterioration/defor med
7.Plug/socket contact	Ensure plug & socket are tightly connected.	



Fuji Xerox Malaysia HQ

**Fuji Xerox Asia Pacific Pte Ltd
Malaysia Operations Headquarters**

No 10 Jalan Bersatu 13/4, 46200 Petaling Jaya, Selangor